PTE20-D4X-23/32T1

Features

- ◆ Up to 10.3125 Gbps data rate
- ◆ 1270nm DFB Tx/1330nm PIN Rx for PTE20-D4X-23T1
- ◆ 1330nm DFB Tx/1270nm PIN Rx for PTE20-D4X-32T1
- ◆ Simplex LC receptacle optical interface compliant
- ◆ Single +3.3V power supply
- ◆ Hot-pluggable
- ◆ AC coupling of CML signals
- ◆ International Class1 laser safety certified
- ◆ Operating temperature range:
Commercial: 0°C~70°C
Industrial: -40°C~85°C
- ◆ RoHS Compliant
- ◆ DDMI function available with internally calibrated mode

Application

- ◆ 10GBASE-LR/LW
- ◆ 10G Fiber Channel

Standard

- ◆ Compliant with MSA SFP+ specification(SFF-8431)
- ◆ Compliant with SFF-8472
- ◆ CPRI Line Rate Option: 9830.4Mbps,
- ◆ Compliant to IEEE 802.3ae

Specification:

Absolute Maximum Ratings				
Parameter	Symbol	Min	Max	Unit
Storage temperature	TS	-40	85	°C
Power Supply Voltage	Vcc	-0.5	+4	V
Relative Humidity	RH	5	95	%

Recommended Operating Conditions					
Parameter	Symbol	Min	Typical	Max	Unit
Operating Case Temperature (Commercial)	Tc	0		70	°C
Operating Case Temperature (Industrial)		-40		85	
Power Supply Voltage	Vcc	3.13	3.3	3.47	V
Supply Current	Icc			300	mA
Data Rate			10.3125		Gbps
Fiber Length 9/125µm core SMF		-	20	-	km

Electrical Characteristics						
Parameter	Symbol	Min	Typical	Max	Unit	Notes
Transmitter differential input voltage		180		850	mV	
Receiver differential output Voltage		300		850	mV	
Transmit Fault (TX_Fault)	Voh	2.4		Vcc+0.3	V	LVTTL
	Vol	-0.3		0.4	V	LVTTL
Loss of Signal (LOS)	Voh	2.4		Vcc+0.3	V	LVTTL
	Vol	-0.3		0.4	V	LVTTL
TX Disable	Vih	2		Vcc+0.3	V	LVTTL
	Vil	-0.3		0.8	V	LVTTL

Optical transmitter Characteristics						
Parameter	Symbol	Min	Typical	Max	Unit	Notes
Launched Power (avg.)	Pout	-5.2		0.5	dBm	
Operating Wavelength Range	λc	1320	1330	1340	nm	PTE20-D4X-32T1

		1260	1270	1280		PTE20-D4X-23T1
Spectral Width	$\Delta\lambda$			1	nm	DFB
Side Mode Suppression Ratio	SMSR	30			dB	
Extinction Ratio	ER	3.5			dB	1
Relative Intensity Noise	RIN			-128	dB/Hz	
Optical Return Loss		12			dB	
Transmitter and Dispersion Penalty	TDP			3.2	dB	
Optical Tx Output disable	Pdis			-45	dBm	
Output Eye Diagram	Complies with IEEE802.3ae eye masks when filtered					
Optical receiver Characteristics						
Parameter	Symbol	Min	Typical	Max	Unit	Notes
Receiver Sensitivity	S			-14.4	dBm	2
Wavelength Range	λ_c	1320		1340	nm	PTE20-D4X-23T1
		1260		1280		PTE20-D4X-32T1
Receiver Reflectance				-12	dB	
Optical Power Input Overload	P_{in-max}	0.5			dBm	2
LOS	Optical De-assert	P_d		-16	dBm	2
	Optical Assert	P_a	-30			
LOS hysteresis		0.5		5	dB	3

Note1. For the measurements, the device was driven with $2^{31}-1$ PRBS pattern

Note2. Measured with a PRBS $2^{31}-1$ test pattern, @10.3125Gbps, ER=4dB, BER< 10^{-12}

Note3. The LOS Hysteresis minimizes 'chatter' on the output line. In principle, Hysteresis alone does not guarantee chatter-free operation.

Digital Diagnostic Monitoring Information

Parameter	Accuracy	Calibration	Note
Temperature	$\pm 3^\circ\text{C}$	internal	-40~85°C
Voltage	$\pm 3\%$	internal	3.1~3.5V
Bias Current	$\pm 10\%$	internal	Specified by normal value
TX Power	$\pm 2\text{dB}$	internal	-5.2~0.5dBm
RX Power	$\pm 2\text{dB}$	internal	-14.4~0.5dBm

Pin Description

The SFP+ modules are hot-pluggable. Hot pluggable refers to plugging in or unplugging a module while the host board is powered. The SFP+ host connector is a 0.8 mm pitch 20 position right angle improved connector specified by SFF-8431, or stacked connector with equivalent electrical performance. Host PCB contact assignment is shown in Figure 1 and contact definitions are given in Table following. SFP+ module contacts mates with the host in the order of ground, power, followed by signal as illustrated by Figure 2 and the contact sequence order listed in the table.

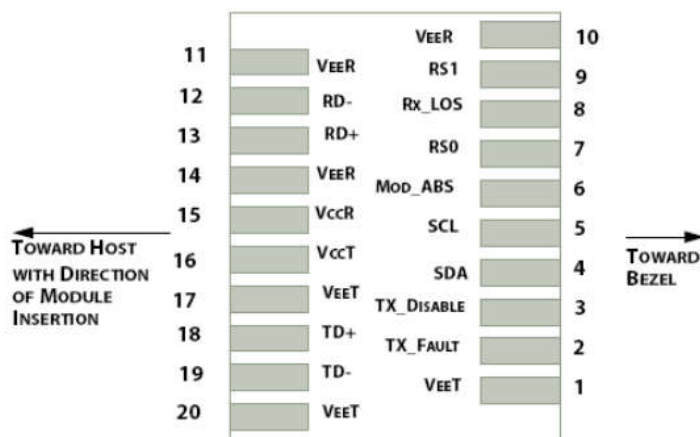

Figure 1 SFP+ Pad Assignment Top View

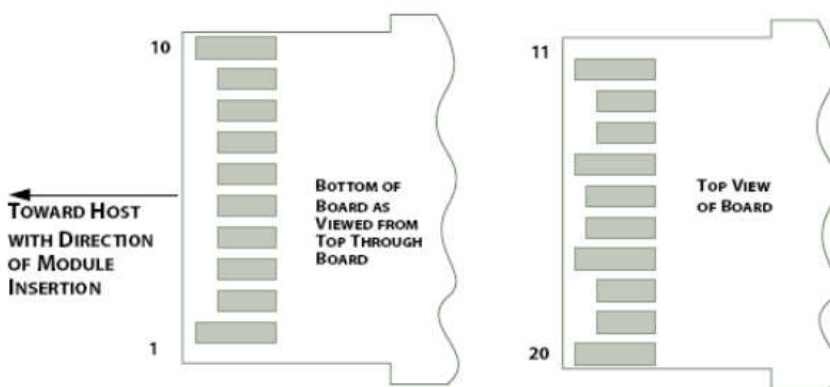

Figure 2 SFP+ Module Contact Assignments

Pin	Symbol	Name/Description	Power Seq.	Ref.
1	VeeT	Transmitter Ground (Common with Receiver Ground)	1st	1
2	TX_Fault	Transmitter Fault, Low: normal; High: abnormal	3rd	2
3	TX_Disable	Transmitter Disable High: Transmitter off Low: Transmitter on	3rd	3
4	SDA	2-Wire Serial Interface Data Line	3rd	4

		(Same as MOD-DEF2 in INF-8074i)		
5	SCL	2-Wire Serial Interface Data Line (Same as MOD-DEF2 in INF-8074i)	3rd	4
6	Mod_ABS	Module Absent, Connect to VeeT or VeeR in Module	3rd	5
7	RS0	Rate Select 0, optionally controls SFP+ module receiver	3rd	6
8	RX_LOS	Receiver Loss of Signal indication High: loss of signal Low: signal detected	3rd	7
9	RS1	Rate Select 1, optionally controls SFP+ module transmitter	3rd	8
10	VeeR	Receiver Ground	1st	1
11	VeeR	Receiver Ground	1st	1
12	RD-	Receiver Inverted DATA out. AC Coupled. CML-O	3rd	9
13	RD+	Receiver Non-inverted DATA out. AC Coupled. CML-O	3rd	9
14	VeeR	Receiver Ground	1st	1
15	VccR	Receiver Power Supply	2nd	10
16	VccT	Transmitter Power Supply	2nd	10
17	VeeT	Transmitter Ground	1st	1
18	TD+	Transmitter Non-Inverted DATA in. AC Coupled. CML-I	3rd	11
19	TD-	Transmitter Inverted DATA in. AC Coupled. CML-I	3rd	11
20	SDA	Transmitter Ground	1st	1

SFP+ Module PIN Definition

Power Seq.: Pin engagement sequence during hot plugging.

Note1. The module signal ground contacts.

Note2. This pin is an open drain/collector and should be pulled up to Vcc-host in the host with a 4.7k~10k Ohm resistor.

Note3. This pin should be pulled up to VccT with a 4.7k~10k Ohm resistor in modules.

Note4. SDA&SCL (IIC) are needed pull up 4.7k~10k Ohm resistors on host board.

Note5. Mod_ABS is connected to VeeT or VeeR in the SFP+ module.

Note6. Rate Select 0, Optionally controls SFP+ module receiver, High: RX input signaling rate > 4.25GBd and Low: RX input signaling rate ≤ 4.25GBd.

Note7. Module RX_Los of signal indication need pull up 4.7k~10k Ohm resistor on host board.

Note8. Rate Select 1, Optionally controls SFP+ module transmitter, High: Tx input signaling rate > 4.25GBd and Low: Tx input signaling rate ≤ 4.25GBd.

Note9. RD -/+ : These are the differential receiver outputs. They are CML AC-coupled with 100 Ohm terminal resistor matching internal.

Note10. VccR and VccT are the receiver and transmitter power supplies.

Note11. TD -/+ : These are the differential transmitter inputs. They are CML AC-coupled with 100 Ohm terminal resistor matching internal.

Block Diagram

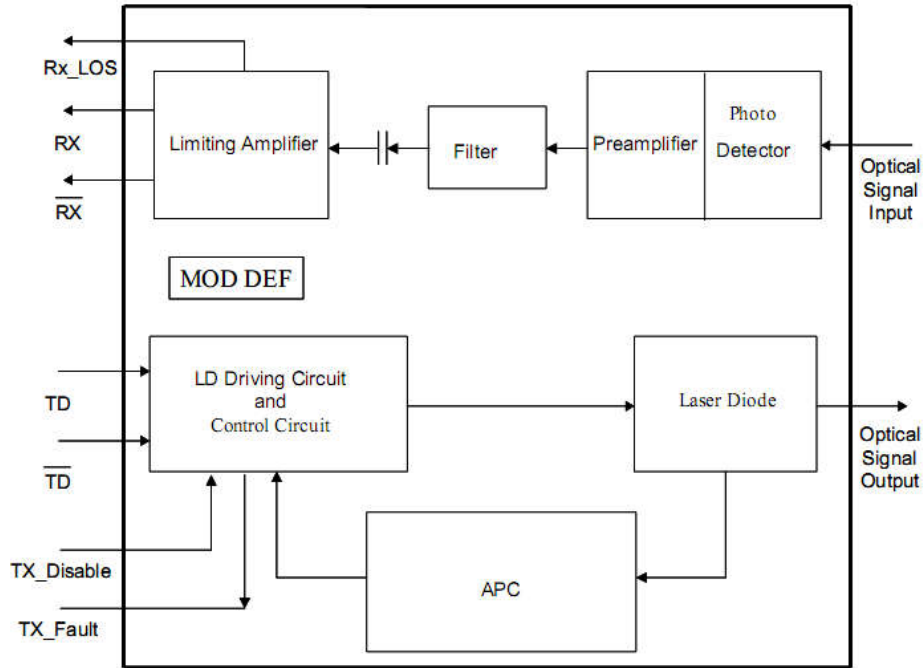

Typical application Circuit

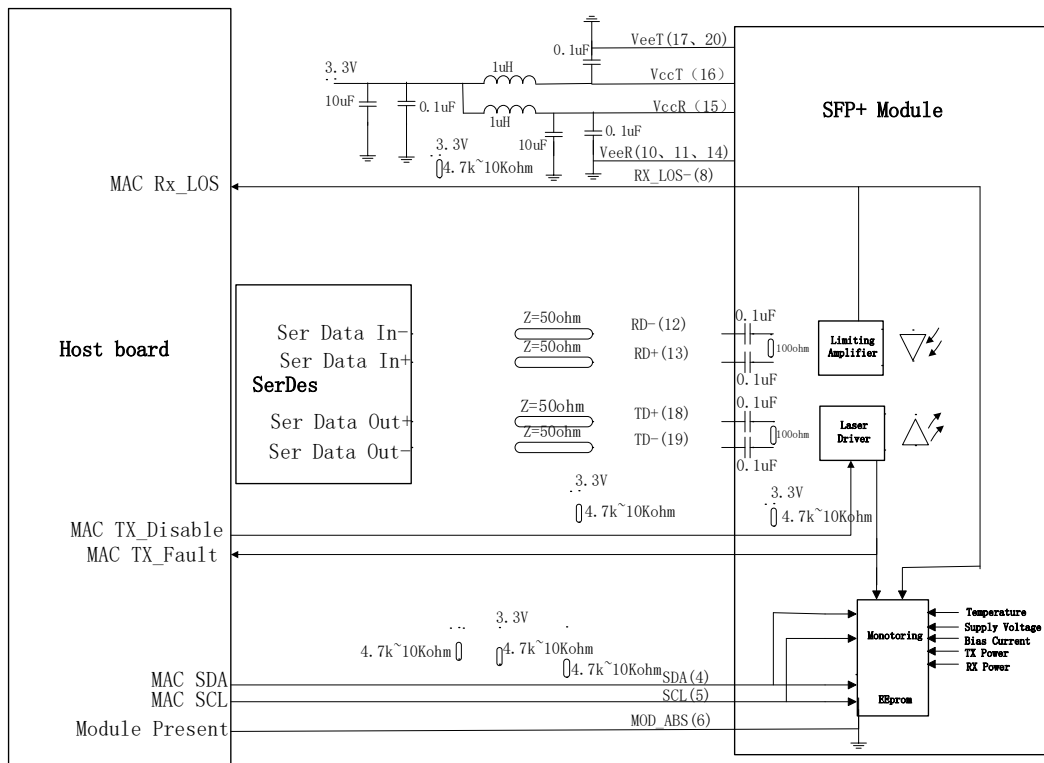

Digital Diagnostic Memory Map

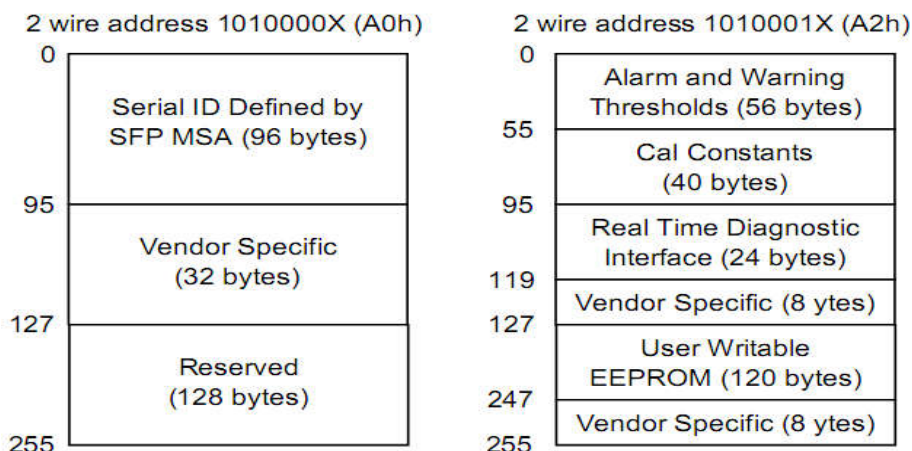

EEPROM Serial ID Memory Contents

The optical transceiver contains an EEPROM. It provides access to sophisticated identification information that describes the transceiver's capabilities, standard interfaces, manufacturer, and other information. When the serial protocol is activated, the host generates the serial clock signal (SCL, Mod Def 1). The positive edge clocks data into those segments of the EEPROM that are not writing protected within the SFP+ transceiver. The negative edge clocks data from the SFP+ transceiver. The serial data signal (SDA, Mod Def 2) is bi-directional for serial data transfer. The host uses SDA in conjunction with SCL to mark the start and end of serial protocol activation. The memories are organized as a series of 8-bit data words that can be addressed individually or sequentially.

The Module provides diagnostic information about the present operating conditions. The transceiver generates this diagnostic data by digitization of internal analog signals. Calibration and alarm/warning threshold data is written during device manufacture. Received power monitoring, transmitted power monitoring, bias current monitoring, supply voltage monitoring and temperature monitoring all are implemented. The diagnostic data are raw A/D values and must be converted to real world units using calibration constants stored in EEPROM locations 56 – 95 at wire serial bus address A2h. The digital diagnostic memory map specific data fields define as following.

EEPROM Serial ID Memory Contents (2-Wire Address A0h)

Address	Name of field	Hex	Description
BASE ID Fields			
00	Identifier	03	SFP/SFP+ transceiver
01	Ext. Identifier	04	Serial ID module supported
02	Connector	07	LC

03-10	Transceiver Codes		
11	Encoding	06	64B/66B
12	BR, Nominal	67	10.3Gbps
13	Rate Identifier	00	Not defined
14	Length(9um)-km	14	20
15	Length(9um)-100m	C8	20000
16	Length(50um)	00	Transceiver transmit distance
17	Length(62.5um)	00	
18	Length(cable)	00	Not support cable
19	Length(OM3)	00	Not support OM3
20-35	Vendor Name	4D 45 4E 54 45 43 48 4F 50 54 4F...	"MENTECHOPTO"(ASCII character)
36	Reserved	00	Not defined
37-39	Vendor OUI	00 00 00	Not defined
40-55	Vendor P/N		PTE20-D4X-23/32T1
56-59	Vendor P/N Rev.	31 2E 30 20	"1.0"(ASCII character)
60-61	Laser Wavelength	04 F6/05 32	1270/1330nm
62	Reserved	00	Not defined
63	CC_BASE	XX	Check sum of bytes 0-62
Extended ID Fields			
64-65	Options	00 1A	RX_LOS, TX_Fault are implemented
66	BR, max	00	Upper bit rate margin,0%
67	BR, min	00	Lower bit rate margin,0%
68-83	Vendor SN		Vendor Serial Number in ASCII character
84-91	Date Code	Data Code	Vendor Date Code in ASCII character
92	Diagnostic Monitoring Type	68	Internally calibrated, RX DDM represents average input optical power
93	Enhanced options	F0	Optional Alarm/warning flags, soft Tx_Disable control and monitoring, soft Tx_Fault and soft RX_LOS monitoring are implemented
94	SFF-8472 compliant	05	SFF-8472 compliant with revision 11.0
95	CC-EXT	XX	Check sum of bytes 64-94
Vendor Specific ID Field			
96-127	Vendor Specific	00	Vendor specific EEPROM
128-255	Reserved	00	Reserved for future use

Digital Diagnostic Monitoring Interface: Alarm and Warning Thresholds

(2-Wire Address A2h)

Address	#Bytes	Name	Real Value		Unit	Hex
			Commercial	Industrial		
00-01	2	Temp High Alarm	80	100	°C	
02-03	2	Temp Low Alarm	-10	-50	°C	
04-05	2	Temp High Warning	70	85	°C	
06-07	2	Temp Low Warning	0	-40	°C	
08-09	2	Voltage High Alarm	3.7		V	
10-11	2	Voltage Low Alarm	3		V	
12-13	2	Voltage High Warning	3.5		V	
14-15	2	Voltage Low Warning	3.1		V	
16-17	2	Bias High Alarm	100		mA	
18-19	2	Bias Low Alarm	1		mA	
20-21	2	Bias High Warning	80		mA	
22-23	2	Bias Low Warning	4		mA	
24-25	2	TX Power High Alarm	2.5		dBm	
26-27	2	TX Power Low Alarm	-7.2		dBm	
28-29	2	TX Power High Warning	0.5		dBm	
30-31	2	TX Power Low Warning	-5.2		dBm	
32-33	2	RX Power High Alarm	2.5		dBm	
34-35	2	RX Power Low Alarm	-16.4		dBm	
36-37	2	RX Power High Warning	0.5		dBm	
38-39	2	RX Power Low Warning	-14.4		dBm	
40-55	16	Reserved	Reserved			

Package Outline

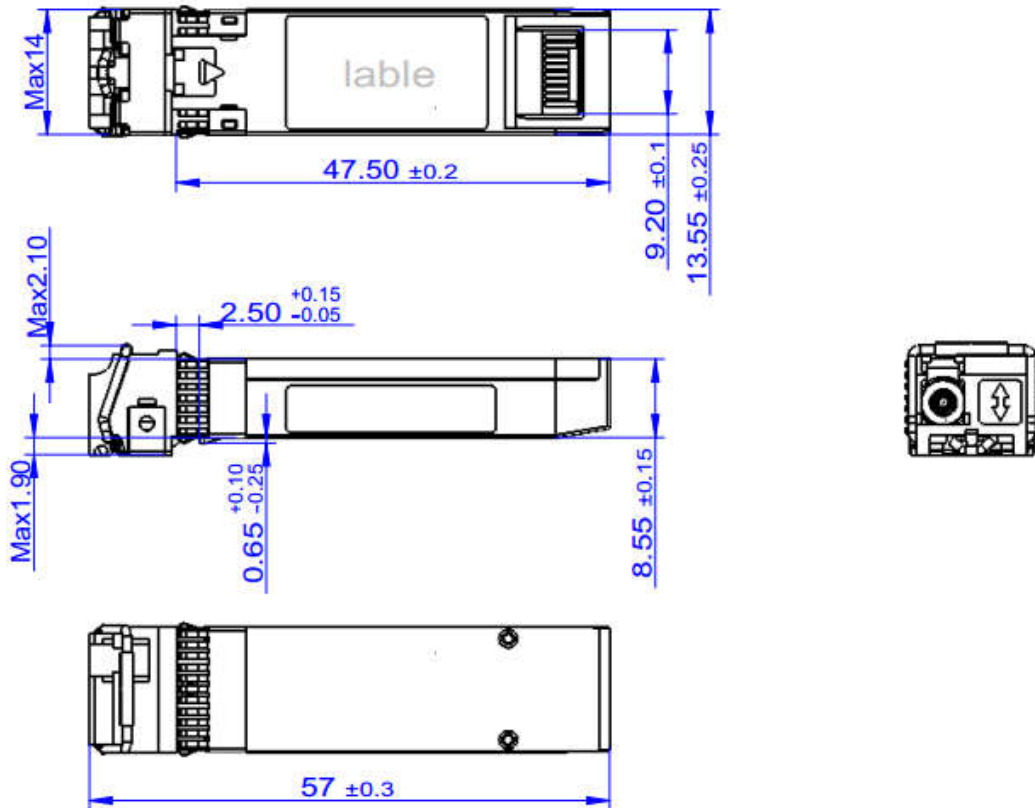

Regulatory Compliance

Feature	Test	Method
Electrostatic Discharge (ESD) to the Electrical Pins	MIL-STD-883E Method 3015.7	Class 1(>1000V for SFI pins, >2000Vfor other pins.)
Electrostatic Discharge (ESD) Immunity	IEC61000-4-2	Class 2(>4.0kV)
Electromagnetic Interference (EMI)	CISPR22 ITE Class B FCC Class B CENELEC EN55022 VCCI Class 1	Comply with standard
Immunity	IEC61000-4-3	Comply with standard
Eye Safety	FDA 21CFR 1040.10 and 1040.11 EN (IEC) 60825-1,2	Compatible with Class I laser Product

Ordering information

Part. No	Specifications								
	Pack	Rate (Gbps)	Tx (nm)	Po (dBm)	RX	Sen (dBm)	Temp (°C)	Reach (km)	DDM
PTE20-D4I-23T1	SFP+	10.3125	1270 DFB	-5.2~0.5	PIN	<-14.4	-40~85	20	Y
PTE20-D4I-32T1	SFP+	10.3125	1330 DFB	-5.2~0.5	PIN	<-14.4	-40~85	20	Y
PTE20-D4C-23T1	SFP+	10.3125	1270 DFB	-5.2~0.5	PIN	<-14.4	0~70	20	Y
PTE20-D4C-32T1	SFP+	10.3125	1330 DFB	-5.2~0.5	PIN	<-14.4	-0~70	20	Y