SOE22-xDCC-xxT1

Features

- ◆ Single Fiber EPON ONU Transceiver
 - 1310nm burst-mode 1.25 Gb/s transmitter with FP laser
 - 1490nm continuous-mode 1.25Gb/s PIN-TIA receiver
- ◆ Compliant with IEEE802.3 ah™ - 2004
- ◆ Compliant with IEC60825 Class I
- ◆ Compliant with SFF-8472 v11.0
- ◆ Digital diagnostic monitoring interface (DDMI) with internal calibration
- ◆ Small Form-Factor Hot Pluggable (SFP) Metallic Package with SC/APC receptacle optical interface
- ◆ Burst On/Off time is less than 16 bits
- ◆ +3.3V separated power supply
- ◆ LVTTTL interface logic level for AC or DC coupled data input
- ◆ CML interface logic level for AC coupled data output
- ◆ LVTTTL for burst signal input
- ◆ LVTTTL for receiver loss of signal detect indication
- ◆ Compliant with RoHS-6
- ◆ Operating temperature range: 0°C~+70°C

Application

- ◆ Gigabit Ethernet P2MP application
- ◆ Gigabit-Ethernet Passive Optical Network (EPON) ONU side
- ◆ FTTx

Description

The transmitter is designed for single mode fiber and operates at wavelength of 1310nm. The transmitter module uses a FP laser diode and fully compliant with IEC60825 and CDRH class 1 eye safety. It contains APC functions, a temperature compensation circuit to ensure compliance with IEEE802.3 ah™ - 2004 requirement at operating temperature, data inputs and AC or DC coupling circuit.

The receiver section uses a hermetic packaged PIN-TIA (PIN with trans-impedance amplifier) and a limiting amplifier. The PIN converts optical power into electrical current and the current is transformed to voltage by the trans-impedance amplifier. The differential DATA and /DATA CML data signals are produced by the limiting amplifier. The PIN-TIA is AC coupled to the limiting amplifier through a low pass filter.

Specification

Absolute Maximum Ratings					
Parameter	Symbol	Min.	Max.	Unit	Note
Storage Ambient Temperature	T _{STG}	-40	85	°C	
Operating Humidity	H _{OPR}	5	95	%	
Power Supply Voltage	V _{CC}	0	4	V	
Input Voltage		GND	V _{CC}	V	
Receiver Damaged Threshold		7		dBm	
Soldering Temperature			260	°C	10s

Recommended Operating Conditions						
Parameter	Symbol	Min.	Typ.	Max.	Unit	Note
Power Supply Voltage	V _{CC}	3.135	3.3	3.465	V	3.3V±5%
Operating Case Temperature	T _{case}	0		70	°C	
Operating Humidity Range	H _{OPR}	5		95	%	
Data Rate			1.25		Gbps	
Data Rate Drift		-100		+100	PPM	

Transmitter Optical and Electrical Characteristics						
Parameter	Symbol	Min.	Typ.	Max.	Unit	Note
Optical Center Wavelength	λ_C	1290	1310	1330	nm	
Optical Spectrum Width (-20dB)	$\Delta \lambda$			1	nm	
Average Launch Power(BOL)	P _{OUT}	0		+4	dBm	1
Average Launch Power-OFF Transmitter	P _{OFF}			-45	dBm	
Extinction Ratio	ER	9			dB	2
Rise/Fall Time (20%-80%)	T _R /T _F			260	ps	3
Burst Turn On Time	T _{BURST_ON}			30	ns	4
Burst Turn Off Time	T _{BURST_OFF}			30	ns	
Burst Enable Duration	T _{EN_DUR}	600			ns	
Burst Disable Duration	T _{DIS_DUR}	100			ns	
Transmitter Reflectance				-10	dB	$\lambda = 1310\text{nm}$
Optical Return Loss Tolerance				15	dB	
RIN ₁₅ OMA				-115	dB/Hz	
Transmitter and Dispersion Penalty	TDP			1.8	dB	
Optical Eye Diagram	Compliant With IEEE Std 802.3ah™ - 2004					2,5
Data Input Differential Swing	V _{IN}	200		1600	mV	6
Input Differential Impedance	Z _{IN}	90	100	110	Ω	
Power Supply Current	I _{CC_TX}			200	mA	
LVTTL Voltage - Low	V _{LVTTL,L}	0		0.8	V	7
LVTTL Voltage - High	V _{LVTTL,H}	2.4		V _{CC}	V	
Total Jitter	T _j			0.2	UI	8

Tx_SD Assert	t_A			200	ns	optional
Tx_SD Deassert	t_D			200	ns	optional

Note 1: Launched into 9/125um SMF, mode 1, 2 are implemented by power leveling mechanism in 2x10 SFP.

Note 2: Measured with PRBS 2⁷-1 test pattern @ 1.25Gbit/s, and the Bessel-Thompson filter is turned on.

Note 3: Measured with PRBS 2⁷-1 test pattern @ 1.25Gbit/s, and the Bessel-Thompson filter is turned off.

Note 4: Refer to Timing Parameter Definition in Burst Mode Sequence.

Note 5: Transmitter eye mask definition in IEEE Std 802.3ah™ - 2004.

Note 6: Compatible with LVPECL input.

Note 7: Included Tx_SD, Tx_Dis or Burst ON, Tx_Fault (See Pin Function Definitions).

Note 8: IEEE Std 802.3ah™ - 2004 Compliant

Receiver Optical and Electrical Characteristics						
Parameter	Symbol	Min.	Typ.	Max.	Unit	Notes
Operating Wavelength	λ_C	1480	1490	1500	nm	
Receiver Sensitivity	P_{SEN}			-27.5	dBm	1
Overload Input Optical Power	P_{SAT}	-3			dBm	
Signal-Detected Assert Level	P_{SDA}			-28	dBm	2
Signal-Detected Deassert Level	P_{SDD}	-39			dBm	3
Signal-Detected Hysteresis	$P_{SDA}-P_{SDD}$	0.5		6	dBm	
Receiver Reflectance				-12	dB	$\lambda = 1490\text{nm}$
1310nm Tx to 1490nm Rx Crosstalk				-45	dB	
Power Supply Current	$I_{CC\ RX}$			120	mA	
Data Output Differential Swing	V_{OUT}	400		1600	mV	4
LVTTTL Voltage - Low	$V_{LVTTL\ L}$	0		0.8	V	5
LVTTTL Voltage - High	$V_{LVTTL\ H}$	2.4		V_{CC}	V	
Signal-Detected Assert Time	T_{ASS}			100	us	
Signal-Detected Deassert Time	T_{DAS}			100	us	

Note 1: Measured with PRBS 2⁷-1 @ 1.25Gbit/s, ER=10dB, BER = 10⁻¹².

Note 2: H-L, A decrease in optical power below the specified level will cause the Signal Detect output to switch from a high state to a low state.

Note 3: L-H, An increase in optical power above the specified level will cause the Signal Detect output to switch from a low state to a high state.

Note 4: CML output, AC coupled internally, guaranteed in the full range of input optical power.

Note 5: Rx_SD

Digital Diagnostic Memory Map

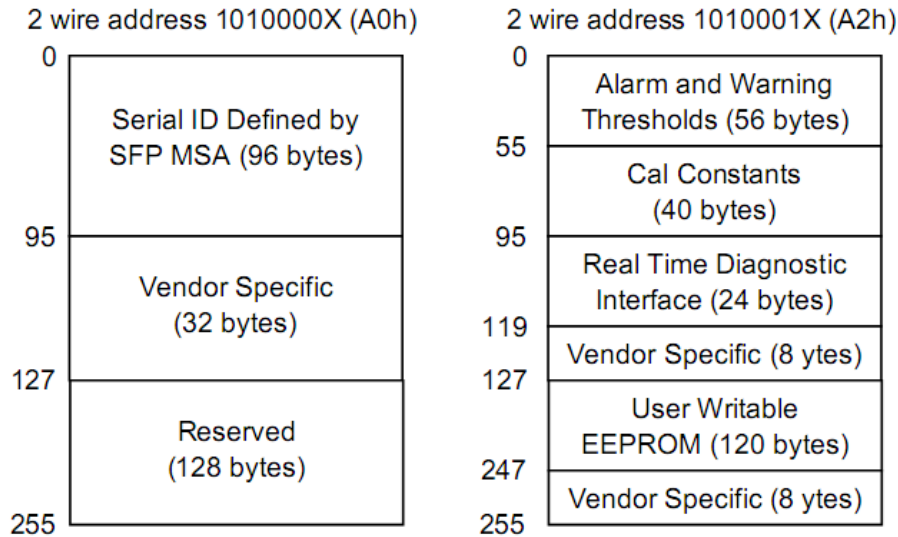

Figure 1

EEPROM Serial ID Memory Contents

The optical transceiver contains an EEPROM. It provides access to sophisticated identification information that describes the transceiver's capabilities, standard interfaces, manufacturer, and other information. When the serial protocol is activated, the host generates the serial clock signal SCL. The positive edge clocks data into those segments of the EEPROM that are not writing protected within the SFP transceiver. The negative edge clocks data from the SFP transceiver. The serial data signal SDA is bi-directional for serial data transfer. The host uses SDA in conjunction with SCL to mark the start and end of serial protocol activation. The memories are organized as a series of 8-bit data words that can be addressed individually or sequentially.

The Module provides diagnostic information about the present operating conditions. The transceiver generates this diagnostic data by digitization of internal analog signals. Calibration and alarm/warning threshold data is written during device manufacture. Received power monitoring, transmitted power monitoring, bias current monitoring, supply voltage monitoring and temperature monitoring all are implemented. The diagnostic data are raw A/D values and must be converted to real world units using calibration constants stored in EEPROM locations 56 – 95 at wire serial bus address A2h. The digital diagnostic memory map specific data fields define as following.

EEPROM Serial ID Memory Contents (2-Wire Address A0h)

Address	Name of field	Hex	Description
BASE ID Fields			
00	Identifier	03	SFP transceiver
01	Ext. Identifier	04	Not defined
02	Connector	01	SC
03-05	Transceiver Codes	00 00 00	Not defined
06	Transceiver Codes	02	1000BASE-LX
07-10	Transceiver Codes	00 00 00 00	Not defined
11	Encoding	01	8B/10B
12	BR, Nominal	0C	1200 MBps
13	Rate Identifier	00	Not defined
14	Length(9um)-km	14	20 km
15	Length(9um)-m	C8	20000 m
16	Length(50um)	00	Transceiver transmit distance
17	Length(62.5um)	00	
18	Length(cable)	00	Not support cable
19	Length(OM3)	00	Not support OM3
20-35	Vendor Name	4D 45 4E 54 45 43 48 4F 50 54 4F 20 20 20 20 20	"MENTECHOPTO"(ASCII character)
36	Reserved	00	Not defined
37-39	Vendor OUI	00 00 00	Not defined
40-55	Vendor P/N	53 4F 45 32 32 2D 4C 44 36 43 2D 41 43 20 20 20	"SOE22-LD6C-AC"(ASCII character)
56-59	Vendor P/N Rev.	31 2E 30 20	"1.0"(ASCII character)
60-61	Laser Wavelength	05 1E	1310nm
62	Reserved	00	Not defined
63	CC_BASE	xx	Check sum of bytes 0-62
Extended ID Fields			
64-65	Options	00 0A	TX_Fault and RX_SD are implemented
66	BR, max	14	1560 MBps
67	BR, min	14	1040 MBps
68-83	Vendor SN	xx xx xx xx xx xx xx xx xx xx xx xx xx xx xx xx xx	Vendor Serial Number in ASCII character
84-91	Date Code	xx xx xx xx xx xx xx xx	Vendor Date Code in ASCII character
92	Diagnostic Monitoring Type	68	Digital Diagnostic monitoring implemented "Internally calibrated" is implemented, RX measurement

			type is "Average Power"
93	Enhanced options	F0	Optional Alarm/warning flags, soft Tx_Disable control and monitoring, soft Tx_Fault and RX_LOS monitoring are implemented
94	SFF-8472 compliant	05	SFF-8472 compliant with revision 11
95	CC-EXT	xx	Check sum of bytes 64-94
Vendor Specific ID Field			
96-127	Vendor Specific	00	Vendor specific EEPROM
128-255	Reserved	00	Reserved for future use

Digital Diagnostic Monitoring Interface: Alarm and Warning Thresholds (2-Wire Address A2h)

Address	#Bytes	Name	Real Value	Unit	Hex
00-01	2	Temp High Alarm	80	°C	
02-03	2	Temp Low Alarm	-10	°C	
04-05	2	Temp High Warning	70	°C	
06-07	2	Temp Low Warning	0	°C	
08-09	2	Voltage High Alarm	3.6	V	
10-11	2	Voltage Low Alarm	3	V	
12-13	2	Voltage High Warning	3.5	V	
14-15	2	Voltage Low Warning	3.1	V	
16-17	2	Bias High Alarm	70	mA	
18-19	2	Bias Low Alarm	2	mA	
20-21	2	Bias High Warning	60	mA	
22-23	2	Bias Low Warning	4	mA	
24-25	2	TX Power High Alarm	6	dBm	
26-27	2	TX Power Low Alarm	-2	dBm	
28-29	2	TX Power High Warning	4	dBm	
30-31	2	TX Power Low Warning	0	dBm	
32-33	2	RX Power High Alarm	0	dBm	
34-35	2	RX Power Low Alarm	-30	dBm	
36-37	2	RX Power High Warning	-3	dBm	
38-39	2	RX Power Low Warning	-27	dBm	
40-55	16	Reserved	Reserved		

Pin Description

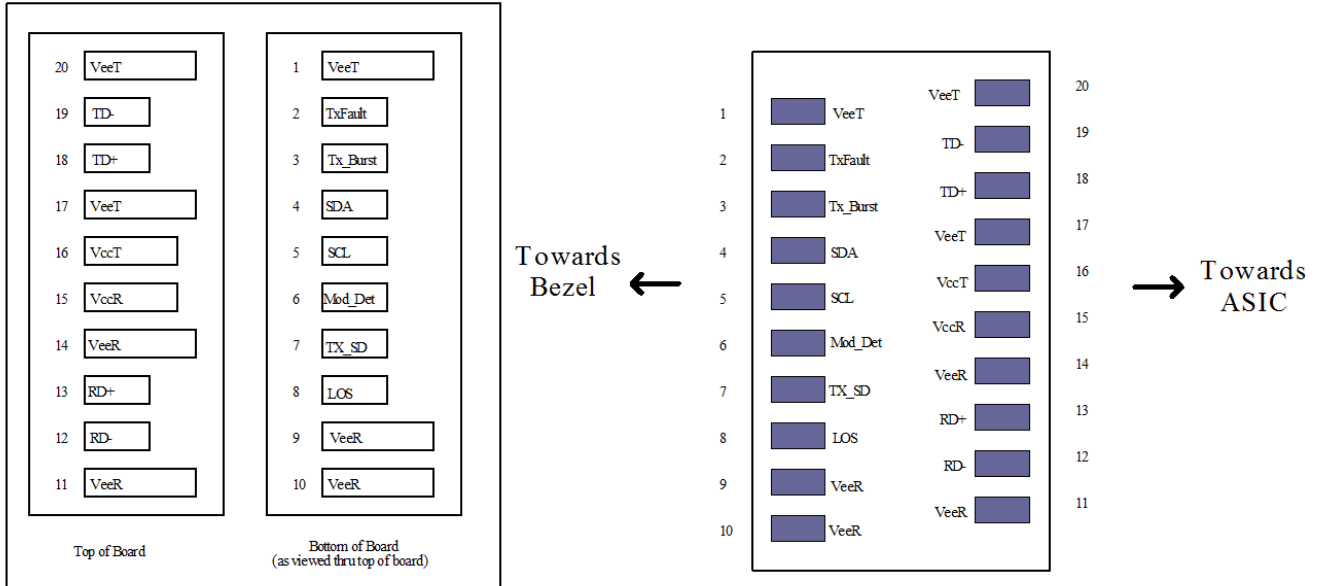

SFP Transceiver Electrical Pad Layout

Host Board Connector Pad Layout

Figure2

Pin Num.	Name	Function	Plug seq.	Note
1	VeeT	Transmitter Ground	1	1
2	TxFault	Transmitter Fault indication	3	2
3	TxBurst	Transmitter Burst control, (LVTTTL)	3	3
4	SDA	Module Definition 2, SDA Serial Data Signal	3	4
5	SCL	Module Definition 1, SCL Serial Clock Signal	3	4
6	MOD_Det	Module Definition 0	3	4
7	TX_SD	Transmitter signal detect	3	5
8	LOS	Loss of Signal, need external 4.7k~10k pull up resistor	3	6
9	VeeR	Receiver Ground (optional no connection)	1	1
10	VeeR	Receiver Ground	1	1
11	VeeR	Receiver Ground	1	1
12	RD-	Inv. Received Data Out (AC coupled)	3	7
13	RD+	Received Data Out (AC coupled)	3	7
14	VeeR	Receiver Ground	1	1
15	VccR	Receiver Power	2	8
16	VccT	Transmitter Power	2	8
17	VeeT	Transmitter Ground	1	1
18	TD+	Transmit Data In (AC coupled)	3	9
19	TD-	Inv. Transmit Data In (AC coupled)	3	9

20	VeeT	Transmitter Ground	1	1
----	------	--------------------	---	---

Plug Seq.: Pin engagement sequence during hot plugging.

Note 1: VeeR and VeeT internally connected within the PON module.

Note 2: TX Fault indicates the status of module with pull up resistor of 10 KΩ externally. Pull up voltage between 2.0V and VccT,

R+0.3V. When high, output indicates a laser fault of some kind. Low indicates normal operation. In the low state, the output will be pulled to < 0.8V.

Note 3: TX disable is an input that is used to shut down the transmitter optical output. It is pulled up within the module with a 10KΩ resistor. (See Timing Parameter Definition in Burst Mode Sequence)

Note 4: These are the module definition pins.

SDA is serial data signal with 10 KΩ pull up resistor externally.

SCL is serial clock signal with 10 KΩ pull up resistor externally.

MOD_Det is grounded internally and need 10 KΩ pull up resistor externally to indicate that the module is present.

Note 5: TX_SD function with 1 KΩ pull up resistor internally ,it monitors the state of the LD laser,when the MAC enables the module,the TX_SD goes high within a short time.

Note 6: LOS (Loss of Signal) indicates the status of received optical power with 10 KΩ pull up resistor externally. Pull up voltage between 2.0V and VccT, R+0.3V. When high, this output indicates the received optical power is below the worst-case receiver sensitivity (as defined by the standard in use). Low indicates normal operation. In the low state, the output will be pulled to < 0.8V.

Note 7: RD -/+: These are the differential receiver outputs. They are AC-coupled with CML voltage level, and required 100ohm resistor to match the differential termination.

Note 8: VccR and VccT are the receiver and transmitter power supplies. They are defined as 3.3V ±5% at the SFP connector pin. Maximum supply current is 300 mA. Recommended host board power supply filtering is shown below. Inductors with DC resistance of less than 1Ω should be used in order to maintain the required voltage at the SFP input pin with 3.3V supply voltage. When the recommended supply filtering network is used, hot plugging of the SFP transceiver module will result in an inrush current of no more than 30 mA greater than the steady state value. VccR and VccT may be internally connected within the SFP transceiver module.

Note 9: TD -/+: These are the differential transmitter inputs. They are AC or DC-coupled, differential lines with 100Ω differential termination inside the module. The AC or DC coupling is done inside the module and is thus not required on the host board.

Function Description

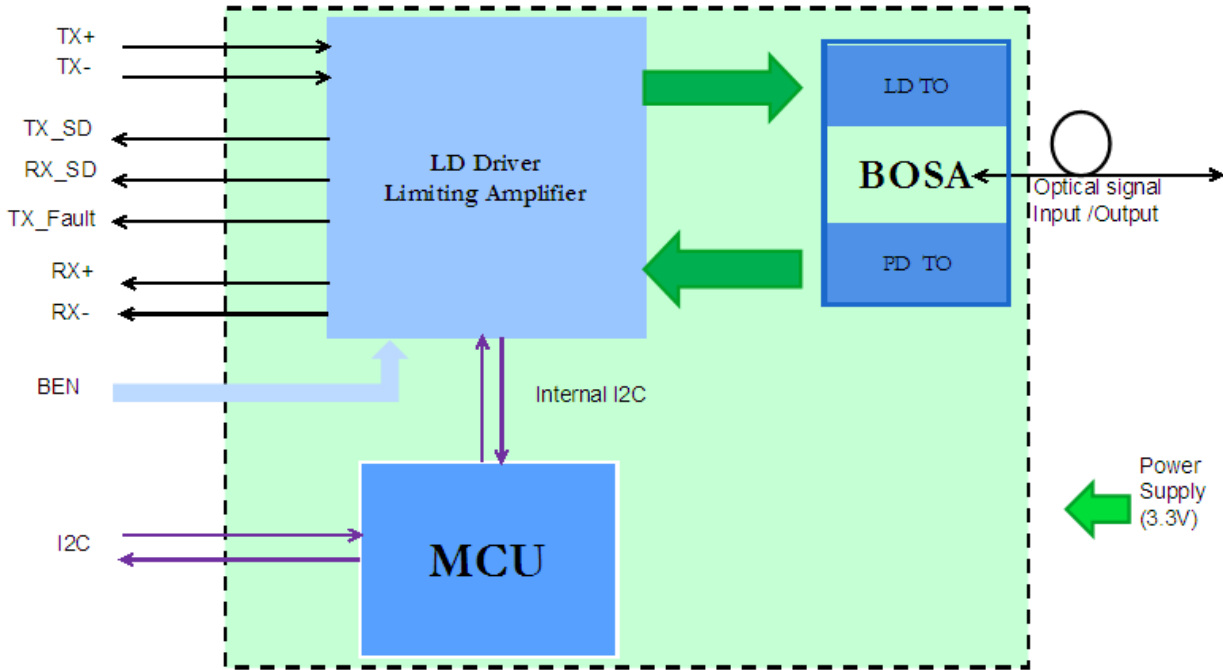

Figure3 Block diagram

The burst-mode transmitter part has a 1310nm FP laser. It features AC or DC-coupled differential data inputs. Tx_Burst is a LVTTL input for TX shut down control. When Tx_Burst is "H", Logic "1" open the LD driver; When Tx_Burst is "L", Logic "0" open the LD driver.

The 1490nm continuous-mode receiver part has a high performance photo detector. The preamplifier (TIA) and limiting amplifier amplify the incoming optical signal into the stable range and convert the signal to differential AC-coupled CML outputs. LOS is LVTTL output, which logic"1" indicates the input power is lower than the threshold, logic"0" indicates the input power is above the threshold.

Interface Circuit

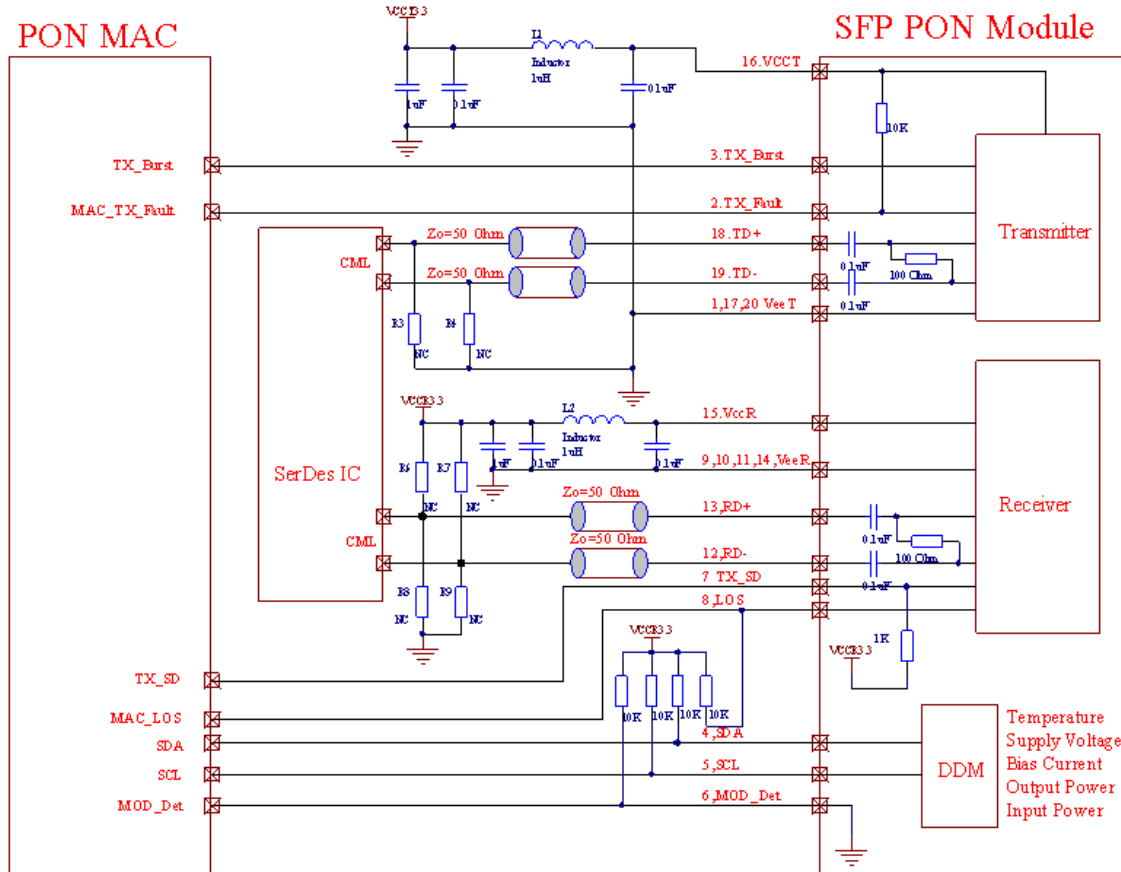
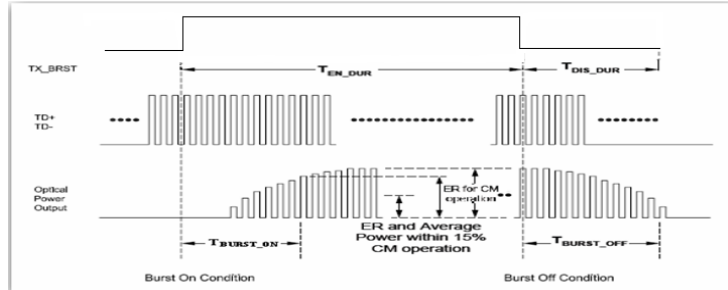

Figure4

Burst Mode Sequence

When the Tx_Burst is "H":



When the Tx_Burst is "L":

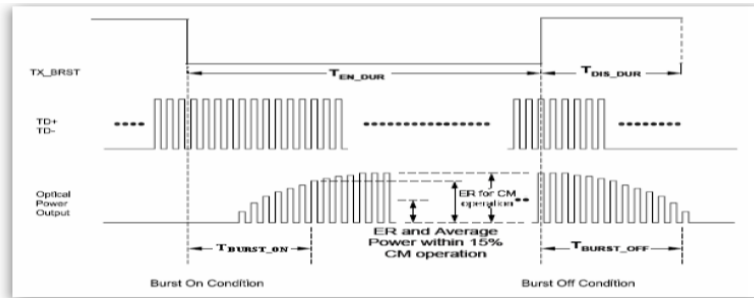

Figure5

Package Outline

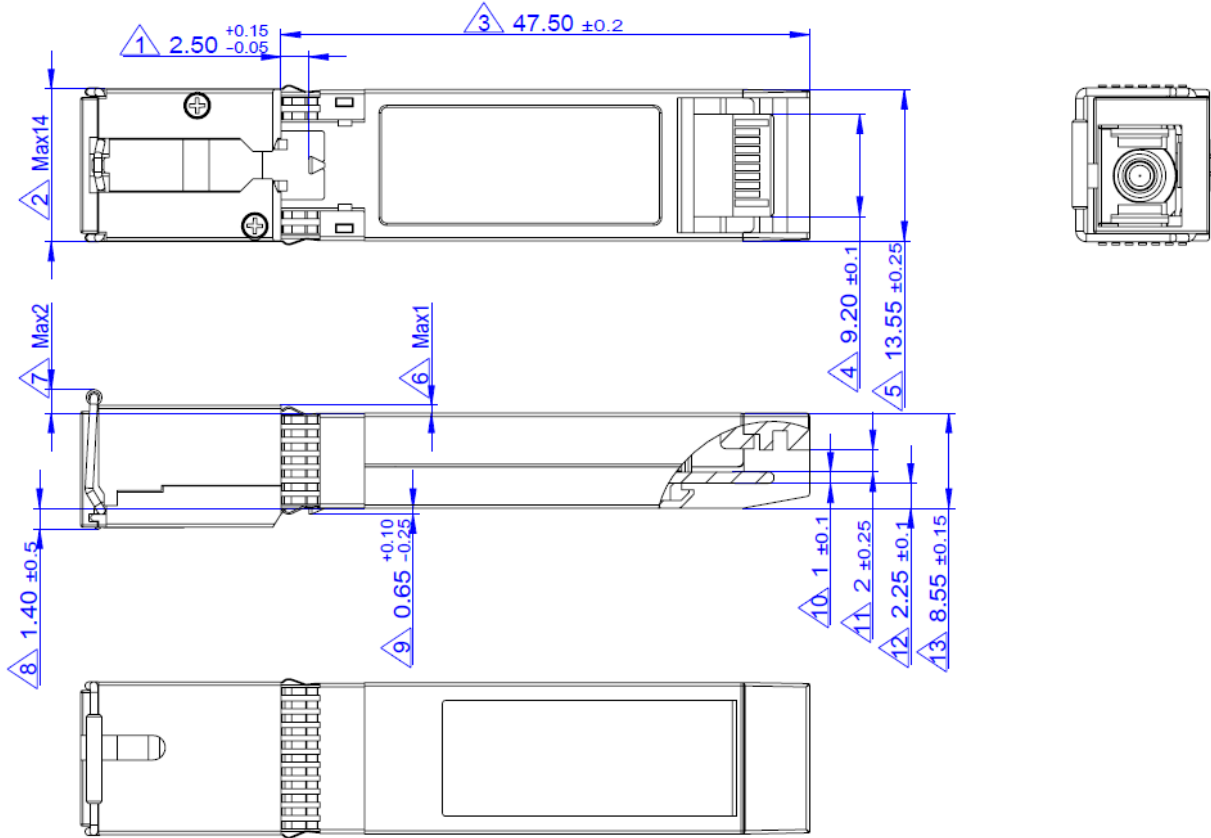

Figure6

Ordering information

PART NO.	Specifications									
	Type	Rate Tx/Rx	Tx (nm)	Po (dBm)	Rx (nm)	Sen (dBm)	Temp (°C)	Reach (Km)	DDM	Others
SOE22-DC C-ACT1	SFP	1.25/1.25 G	1310 FP	0~4	1490 PIN	<-27.5	0~+70	20	Y	SC/APC Receptacle, High-Burst On, TD+/-:AC
SOE22-DC C-DCT1	SFP	1.25/1.25 G	1310 FP	0~4	1490 PIN	<-27.5	0~+70	20	Y	SC/APC Receptacle, High-Burst On, TD+/-:DC
SOE22-LD CC-ACT1	SFP	1.25/1.25 G	1310 FP	0~4	1490 PIN	<-27.5	0~+70	20	Y	SC/APC Receptacle, LOW-Burst On, TD+/-:AC
SOE22-LD CC-DCT1	SFP	1.25/1.25 G	1310 FP	0~4	1490 PIN	<-27.5	0~+70	20	Y	SC/APC Receptacle, LOW -Burst On, TD+/-:DC