

---

# NOE22-xD9I-xxT1

## Features

- ◆ Single Fiber EPON ONU Transceiver
  - 1310nm burst-mode 1.25 Gb/s transmitter with FP laser
  - 1490nm continuous-mode 1.25Gb/s PIN-TIA receiver
- ◆ Compliant with IEEE802.3 ah™ - 2004
- ◆ Compliant with IEC60825 Class I
- ◆ Digital diagnostic monitoring interface (DDMI) with internal calibration
- ◆ 2x10 Small Form Factor (SFF) Metallic Package with SC/APC pigtail optical interface
- ◆ Burst On/Off time is less than 16 bits
- ◆ +3.3V separated power supply
- ◆ LVTTL interface logic level for AC or DC coupled data input
- ◆ CML interface logic level for AC coupled data output
- ◆ LVTTL for burst signal input
- ◆ LVTTL for receiver loss of signal detect indication
- ◆ Compliant with RoHS-6
- ◆ Operating temperature range: -40°C~+85°C

## Applications

- ◆ Gigabit Ethernet P2MP application
- ◆ Gigabit-Ethernet Passive Optical Network (EPON) ONU side
- ◆ FTTx

## Description

The transmitter is designed for single mode fiber and operates at wavelength of 1310nm. The transmitter module uses a FP laser diode and fully compliant with IEC60825 and CDRH class 1 eye safety. It contains APC functions, a temperature compensation circuit to ensure compliance with IEEE802.3 ah™ - 2004 requirement at operating temperature, data inputs and AC or DC coupling circuit.

The receiver section uses a hermetic packaged PIN-TIA (PIN with trans-impedance amplifier) and a limiting amplifier. The PIN converts optical power into electrical current and the current is transformed to voltage by the trans-impedance amplifier. The differential DATA and /DATA CML data signals are produced by the limiting amplifier. The PIN-TIA is AC coupled to the limiting amplifier through a low pass filter.

## Specification

Absolute Maximum Ratings					
Parameter	Symbol	Min.	Max.	Unit	Note
Storage Ambient Temperature	T <sub>STG</sub>	-40	85	°C	
Operating Humidity	H <sub>OPR</sub>	5	95	%	
Power Supply Voltage	V <sub>CC</sub>	0	4	V	
Input Voltage		GND	V <sub>CC</sub>	V	
Receiver Damaged Threshold		7		dBm	
Soldering Temperature			260	°C	10s

Recommended Operating Conditions						
Parameter	Symbol	Min.	Typ.	Max.	Unit	Note
Power Supply Voltage	V <sub>CC</sub>	3.135	3.3	3.465	V	3.3V±5%
Operating Case Temperature	T <sub>case</sub>	-40		85	°C	
Operating Humidity Range	H <sub>OPR</sub>	5		95	%	
Data Rate			1250		Mbps	
Data Rate Drift		-100		100	PPM	

Transmitter Optical and Electrical Characteristics						
Parameter	Symbol	Min.	Typ.	Max.	Unit	Note
Optical Center Wavelength	λ <sub>C</sub>	1260	1310	1360	nm	
RMS Spectrum Width	Δλ	compliance with 802.3ah Px20+			nm	
Average Launch Power	P <sub>OUT</sub>	0		4	dBm	1
Average Launch Power-OFF Transmitter	P <sub>OFF</sub>			-45	dBm	
Extinction Ratio	ER	9			dB	2
Rise/Fall Time (20%-80%)	T <sub>R</sub> /T <sub>F</sub>			260	ps	8
Burst Turn On Time	T <sub>BURST_ON</sub>			30	ns	3
Burst Turn Off Time	T <sub>BURST_OFF</sub>			30	ns	
Burst Enable Duration	T <sub>EN_DUR</sub>	600			ns	
Burst Disable Duration	T <sub>DIS_DUR</sub>	100			ns	
Transmitter Reflectance				-10	dB	λ=1310nm
Optical Return Loss Tolerance		15			dB	
RIN <sub>15</sub> OMA				-115	dB/Hz	
Transmitter and Dispersion Penalty	TDP			1.8	dB	
Optical Eye Diagram	Compliant With IEEE Std 802.3ah™ - 2004 1000BASE-PX20+					2,4
Data Input Differential Swing	V <sub>IN</sub>	200		1600	mV	5
Input Differential Impedance	Z <sub>IN</sub>	90	100	110	Ω	
Power Supply Current	I <sub>CC_TX</sub>			200	mA	CW
LVTTL Voltage - Low	V <sub>LVTTL,L</sub>	0		0.8	V	6

LVTTL Voltage - High	$V_{LVTTLL,H}$	2.4		Vcc	V	
Total Jitter	$T_j$			0.2	UI	7
Tx_SD Assert	$t_A$			200	ns	optional
Tx_SD Deassert	$t_D$			200	ns	optional

Note 1: Launched into 9/125um SMF.

Note 2: Measured with PRBS 2<sup>7</sup>-1 test pattern @1250Mbit/s, and the Bessel-Thompson filter is turned on.

Note 3: Refer to Timing Parameter Definition in Burst Mode Sequence.

Note 4: Transmitter eye mask definition in IEEE Std 802.3ah™ - 2004 1000BASE-PX20+.

Note 5: Compatible with LVPECL input.

Note 6: Included Tx\_SD, Tx\_Dis or Burst ON, Tx\_Fault (See Pin Function Definitions).

Note 7: IEEE Std 802.3ah™ - 2004 1000BASE-PX20+ Compliant

Note 8: Measured with PRBS 2<sup>7</sup>-1 test pattern @1250Mbit/s, and the Bessel-Thompson filter is turned off.

Note 9: All test at full operating temperature.

Receiver Optical and Electrical Characteristics						
Parameter	Symbol	Min.	Typ.	Max.	Unit	Notes
Operating Wavelength	$\lambda_C$	1480	1490	1500	nm	
Receiver Sensitivity	$P_{SEN}$			-27	dBm	1
Overload Input Optical Power	$P_{SAT}$	-3			dBm	
Signal-Detected Assert Level	$P_{SDA}$			-28	dBm	2
Signal-Detected Deassert Level	$P_{SDD}$	-39			dBm	3
Signal-Detected Hysteresis	$P_{SDA}-P_{SDD}$	0.5	2.5	6	dBm	
Receiver Reflectance				-12	dB	$\lambda=1490nm$
1310nm Tx to 1490nm Rx Crosstalk				-45	dB	
Power Supply Current	$I_{CC,RX}$			120	mA	
Data Output Differential Swing	$V_{OUT}$	300		1200	mV	4
LVTTL Voltage - Low	$V_{LVTTLL}$	0		0.4	V	
LVTTL Voltage - High	$V_{LVTTLL,H}$	2.4		Vcc	V	
Signal-Detected Assert Time	$T_{ASS}$			100	us	
Signal-Detected Deassert Time	$T_{DAS}$			100	us	

Note 1: Measured with PRBS 2<sup>7</sup>-1 test pattern @1250Mbit/s, ER=10dB, BER =10<sup>-12</sup>.

Note 2:H-L, A decrease in optical power below the specified level will cause the Signal Detect output to switch from a high state to a low state.

Note 3: L-H,An increase in optical power above the specified level will cause the Signal Detect output to switch from a low state to a high state.

Note 4: CML output, AC coupled internally, guaranteed in the full range of input optical power.

Note 5: All test at full operating temperature.

## Digital Diagnostic Memory Map

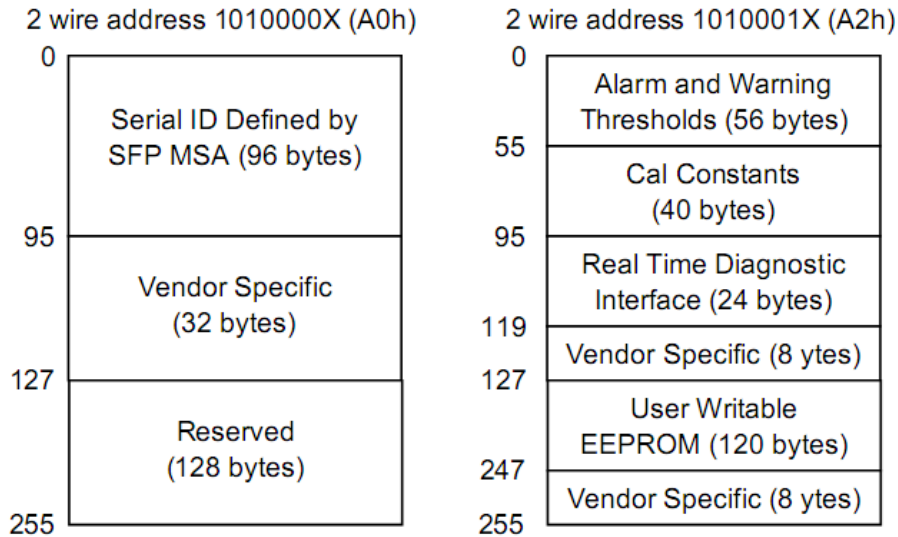

Figure1

## EEPROM Serial ID Memory Contents

The optical transceiver contains an EEPROM. It provides access to sophisticated identification information that describes the transceiver's capabilities, standard interfaces, manufacturer, and other information. When the serial protocol is activated, the host generates the serial clock signal SCL. The positive edge clocks data into those segments of the EEPROM that are not writing protected within the SFF transceiver. The negative edge clocks data from the SFF transceiver. The serial data signal SDA is bi-directional for serial data transfer. The host uses SDA in conjunction with SCL to mark the start and end of serial protocol activation. The memories are organized as a series of 8-bit data words that can be addressed individually or sequentially.

The Module provides diagnostic information about the present operating conditions. The transceiver generates this diagnostic data by digitization of internal analog signals. Calibration and alarm/warning threshold data is written during device manufacture. Received power monitoring, transmitted power monitoring, bias current monitoring, supply voltage monitoring and temperature monitoring all are implemented. The diagnostic data are raw A/D values and must be converted to real world units using calibration constants stored in EEPROM locations 56 – 95 at wire serial bus address A2h. The digital diagnostic memory map specific data fields define as following.

**EEPROM Serial ID Memory Contents (2-Wire Address A0h)**

Address	Name of field	Hex	Description
<b>BASE ID Fields</b>			
00	Identifier	02	SFF transceiver
01	Ext. Identifier	08	Not defined
02	Connector	0B	Optical pigtail
03-05	Transceiver Codes	00 00 00	Not defined
06	Transceiver Codes	02	1000BASE-LX
07-10	Transceiver Codes	00 00 00 00	Not defined
11	Encoding	01	8B/10B
12	BR, Nominal	0D	1300 MBps
13	Rate Identifier	00	Not defined
14	Length(9um)-km	14	20 km
15	Length(9um)-m	C8	20000 m
16	Length(50um)	00	Transceiver transmit distance
17	Length(62.5um)	00	
18	Length(cable)	00	Not support cable
19	Length(OM3)	00	Not support OM3
20-35	Vendor Name	4D 45 4E 54 45 43 48 4F 50 54 4F 20 20 20 20 20	"MENTECHOPTO"(ASCII character)
36	Reserved	00	Not defined
37-39	Vendor OUI	00 00 00	Not defined
40-55	Vendor P/N	4E 4F 45 32 32 2D 4C 44 38 49 2D 41 43 20 20 20	"NOE22-LD8I-AC"(ASCII character)
56-59	Vendor P/N Rev.	31 2E 30 20	"1.0"(ASCII character)
60-61	Laser Wavelength	05 1E	1310nm
62	Reserved	00	Not defined
63	CC_BASE	xx	Check sum of bytes 0-62
<b>Extended ID Fields</b>			
64-65	Options	00 1C	TX_Disable、TX_Faultand RX_SD are implemented
66	BR, max	14	1560 MBps
67	BR, min	14	1040 MBps
68-83	Vendor SN	xx xx xx xx xx xx xx xx xx xx xx xx xx xx xx	Vendor Serial Number in ASCII character
84-91	Date Code	xx xx xx xx xx xx xx xx	Vendor Date Code in ASCII character
92	Diagnostic Monitoring Type	68	Digital Diagnostic monitoring implemented "Internally calibrated "

			is implemented, RX measurement type is "Average Power"
93	Enhanced options	E0	Optional Alarm/warning flags, soft Tx_Disable control and monitoring, soft Tx_Fault monitoring are implemented
94	SFF-8472 compliant	02	SFF-8472 compliant with revision 9.5
95	CC-EXT	xx	Check sum of bytes 64-94
<b>Vendor Specific ID Field</b>			
96-127	Vendor Specific	00	Vendor specific EEPROM
128-255	Reserved	00	Reserved for future use

**Digital Diagnostic Monitoring Interface: Alarm and Warning Thresholds (2-Wire Address A2h)**

Address	#Bytes	Name	Real Value	Unit	Hex
00-01	2	Temp High Alarm	90	°C	
02-03	2	Temp Low Alarm	-45	°C	
04-05	2	Temp High Warning	85	°C	
06-07	2	Temp Low Warning	-40	°C	
08-09	2	Voltage High Alarm	3.6	V	
10-11	2	Voltage Low Alarm	3	V	
12-13	2	Voltage High Warning	3.5	V	
14-15	2	Voltage Low Warning	3.1	V	
16-17	2	Bias High Alarm	70	mA	
18-19	2	Bias Low Alarm	2	mA	
20-21	2	Bias High Warning	60	mA	
22-23	2	Bias Low Warning	4	mA	
24-25	2	TX Power High Alarm	6	dBm	
26-27	2	TX Power Low Alarm	-2	dBm	
28-29	2	TX Power High Warning	4	dBm	
30-31	2	TX Power Low Warning	0	dBm	
32-33	2	RX Power High Alarm	0	dBm	
34-35	2	RX Power Low Alarm	-30	dBm	
36-37	2	RX Power High Warning	-3	dBm	
38-39	2	RX Power Low Warning	-27	dBm	
40-55	16	Reserved	Reserved		

## Pin Description

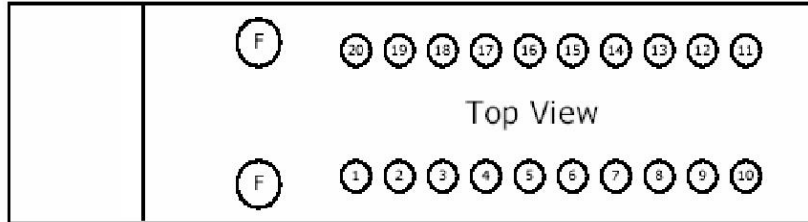

Figure2

Pin No	Name	Default Description	Note
1	NC	No Function Definition	
2	GND	Ground	
3	GND	Ground	
4	NC	No Function Definition	
5	NC	No Function Definition	
6	V <sub>EER</sub>	Receiver Signal Ground	
7	V <sub>CCR</sub>	Receiver Power Supply	
8	Rx_SD	Receiver Signal-Detected Indication (LVTTTL), internally pull up, (LVTTTL) "1": Optical Signal-Detected.	1
9	RD-	Inverted Receiver Data Output(CML/AC coupled internally)	
10	RD+	Non-inverted Receiver Data Output(CML/AC coupled internally)	
11	V <sub>CCT</sub>	Transmitter Power Supply	
12	V <sub>EET</sub>	Transmitter Signal Ground	
13	Tx_Burst	Transmitter Burst Control (LVTTTL)	2
14	TD+	Non-inverted Transmitter Data Input	3
15	TD-	Inverted Transmitter Data Input	3
16	V <sub>EET</sub>	Transmitter Signal Ground	
17	SCL	Clock Line of the I <sup>2</sup> C interface (LVTTTL)	4
18	SDA	Data Line of the I <sup>2</sup> C interface (LVTTTL)	4
19	Tx_Fault	Transmitter Fault Indication (LVTTTL), internally pull up, "1": Fault.	
20	Tx_SD	Transmitter Signal-Detected Indication (LVTTTL), "1": Optical Signal-Detected.	5
F	MS	Mounting Studs	6

Note 1: LVTTTL logic output, with internal 10KΩ pull-up resistor. Optical Signal-Detected: High.

Note 2: A positive level enable optical signal output under burst mode. Optional, a negative level enable.

(See Timing Parameter Definition in Burst Mode Sequence)

Note 3: Optional AC or DC coupled internally.

Note 4: I<sup>2</sup>C interface, they should be pulled up with two 4.7-10KΩ resistors on the host board.

Note 5: Optional Tx\_SD.

Note 6: The mounting studs are provided for transceiver mechanical attachment to circuit board. They may also provide an optional connection of the transceiver to the equipment chassis ground. The holes in the circuit board must be tied to chassis ground. It is not recommended that the mounting studs be connected to signal ground.



## Function Description

The transceiver provides high-speed Bi-directional serial optical link for EPON application up to 20km.

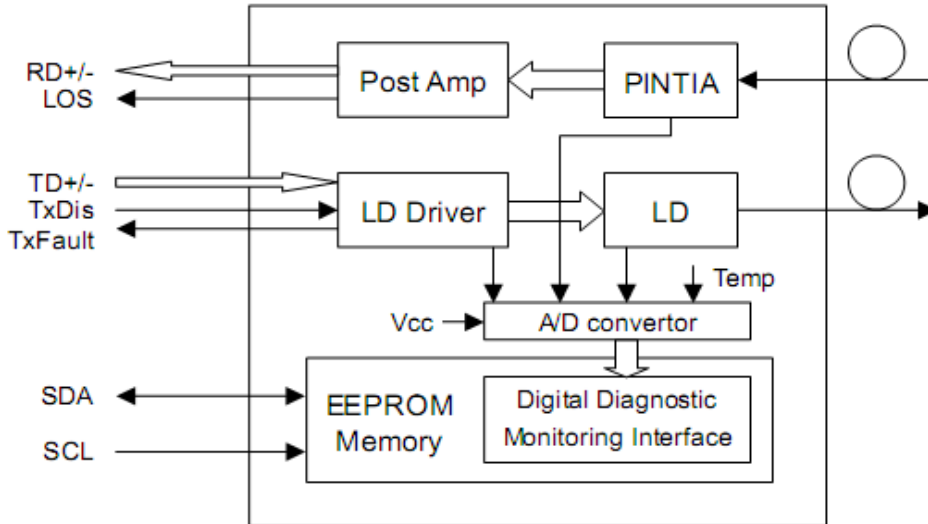

Figure3 Block diagram

The burst-mode transmitter part has a 1310nm FP laser. It features AC or DC-coupled differential data inputs. Tx\_Burst is a LVTTTL input for TX shut down control. When Tx\_Burst is "H", Logic "1" open the LD driver; When Tx\_Burst is "L", Logic "0" open the LD driver.

The 1490nm continuous-mode receiver part has a high performance photo detector. The preamplifier (TIA) and limiting amplifier amplify the incoming optical signal into the stable range and convert the signal to differential AC-coupled outputs. SD is LVTTTL output, which logic"0" indicates the input power is lower than the threshold, logic"1" indicates the input power is above the threshold.



## Interface Circuit

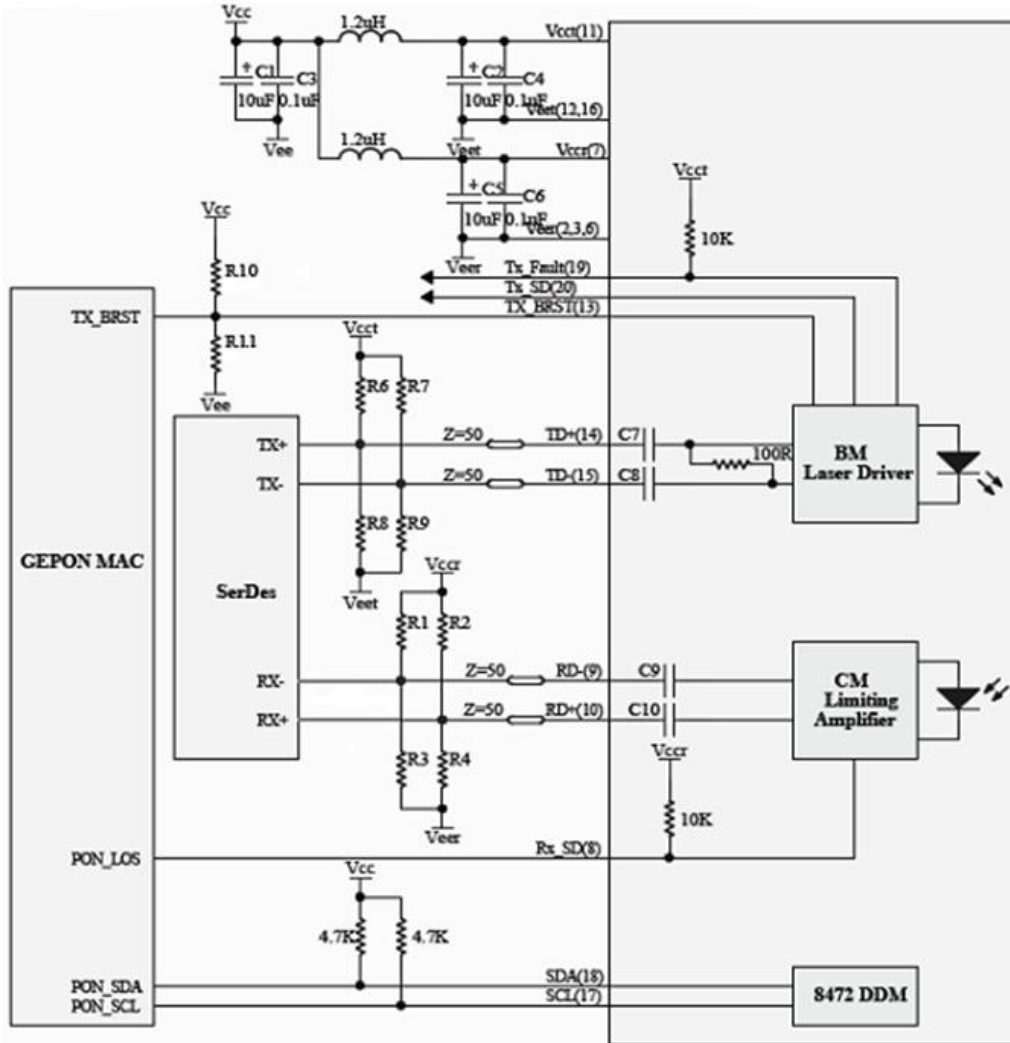

Figure4

Note A: When the Tx\_Burst is "H", The configure is R10=NC, R11=10K;

When the Tx\_Burst is "L", The configure is R10=10K, R11=NC;

Note B: When input is "DC" coupled internally, The configure is R6=R7=130Ω, R8=R9=82Ω, C7=C8=0Ω;

When input is "AC" coupled internally, The configure is R6=R7=R8=R9=NC, C7=C8=0.1uF;

Note C: For LVPECL output, AC coupled internally, R1=R2=82Ω, R3=R4=130Ω;

Other the R1=R2=R3=R4=NC;

## Burst Mode Sequence

When the Tx\_Burst is "H":

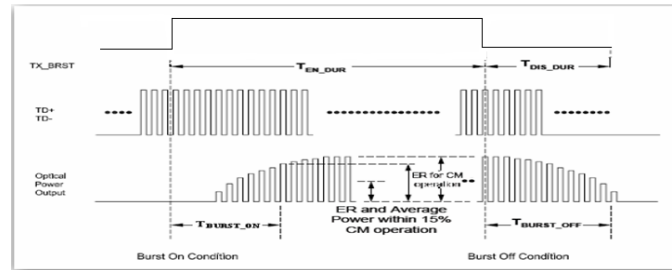

When the Tx\_Burst is "L":

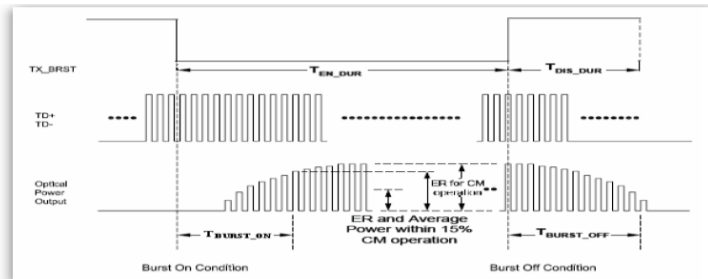

Figure5

## Regulatory Compliance

Feature	Test	Method
Electrostatic Discharge (ESD) to the Electrical Pins	MIL-STD-883E Method 3015.7	Class 1 (>1.5kV) – Human Body Model
Electrostatic Discharge (ESD) Immunity	IEC61000-4-2	Class 2 (>4.0kV)
Electromagnetic Interference (EMI)	CISPR22 ITE Class B EN55022 Class B	Compliant with standards
Immunity	IEC61000-4-3 Class 2 EN55024	Typically show no measurable effect from a 3V/m field swept from 80 to 1000MHz applied to the transceiver without a chassis enclosure.
Eye Safety	FDA 21 CFR 1040.10 and 1040.11 UL TUV EN 60825-1	Compliant with Class 1 laser product
Component Recognition	UL and CSA	Compliant with standards
RoHS	2002/95/EC 4.1&4.2	Compliant with standards

**Package Outline**

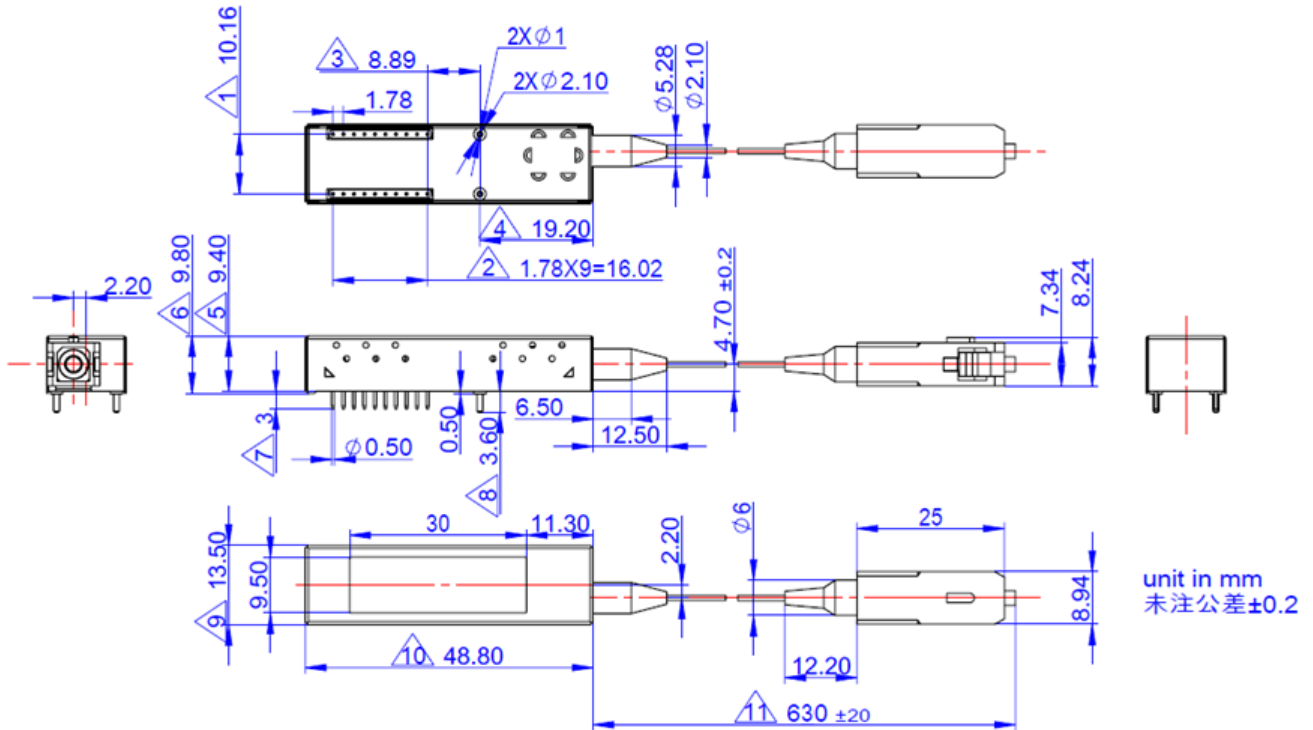

Figure6

## Ordering information

PART NO.	Specifications									
	Type	Rate Tx/Rx	Tx (nm)	Po (dBm)	Rx (nm)	Sen (dBm)	Temp (°C)	Reach (Km)	DDM	Others
NOE22-D9 I-ACT1	SFF	1.25/1.25 G	1310 FP	0~4	1490 PIN	<-27	-40~+85	20	Y	SC/APC pigtail, High-Burst On, TD+/-:AC
NOE22-D9 I-DCT1	SFF	1.25/1.25 G	1310 FP	0~4	1490 PIN	<-27	-40~+85	20	Y	SC/APC pigtail, High-Burst On, TD+/-:DC
NOE22-LD 9I-ACT1	SFF	1.25/1.25 G	1310 FP	0~4	1490 PIN	<-27	-40~+85	20	Y	SC/APC pigtail, LOW-Burst On, TD+/-:AC
NOE22-LD 9I-DCT1	SFF	1.25/1.25 G	1310 FP	0~4	1490 PIN	<-27	-40~+85	20	Y	SC/APC pigtail, LOW-Burst On, TD+/-:DC