S4FD2-D0X-8VT1

Features

- u Up to 4.25Gbps data rate
- u 850nm VCSEL Laser and PIN photo detector
- u Duplex LC receptacle optical interface compliant
- u Single +3.3V power supply
- u Hot-pluggable
- u AC coupling of LVPECL signals
- u International Class1 laser safety certified
- u Operating temperature range:
Commercial:0°C~+70°C
Extended : -20°C~+85°C
- u RoHS Compliant
- u DDMI function available with internally calibrated mode

Application

- u Tri-Rate 1.063/2.125/4.25 Gb/s
- u Wireless – OBSAI, CPRI

Standard

- u Compliant with MSA SFP specification
- u Compliant with SFF-8472
- u Compliant with FC-PI v2.0

Specification

Absolute Maximum Ratings				
Parameter	Symbol	Min	Max	Unit
Storage temperature	TS	-40	85	°C
Power Supply Voltage	Vcc	-0.5	+4	V
Relative Humidity	RH	5	95	%

Recommended Operating Conditions					
Parameter	Symbol	Min	Typical	Max	Unit
Operating CaseTemperature (Commercial)	Tc	0		70	°C
Operating CaseTemperature (Extended)		-20		85	
Power Supply Voltage	Vcc	3.13	3.3	3.47	V
Supply Current	Icc			240	mA
Data Rate			4.25		Gbps
Fiber Length 62.5µm core MMF (4.25Gbps)				70	m
Fiber Length 50µm core MMF (4.25Gbps)		-	-	150	

Electrical Characteristics						
Parameter	Symbol	Min	Typical	Max	Unit	Notes
Transmitter differential input voltage		400		2400	mV	
Receiver differential output Voltage		600		1200	mV	
Transmit Fault (TX_Fault)	Voh	2.4		Vcc+0.3	V	LVTTL
	Vol	-0.3		0.4	V	LVTTL
Loss of Signal (LOS)	Voh	2.4		Vcc+0.3	V	LVTTL
	Vol	-0.3		0.4	V	LVTTL
TX Disable	Vih	2		Vcc+0.3	V	LVTTL
	Vil	-0.3		0.8	V	LVTTL

Optical transmitter Characteristics						
Parameter	Symbol	Min	Typical	Max	Unit	Notes
Launched Power (avg.)	Pout	-9		-2.5	dBm	BOL

Operating Wavelength Range	λ_c	830	850	860	nm	
Spectral Width (RMS)	$\Delta\lambda$			0.85	nm	
Optical Modulation Amplitude @ 4.25 Gb/s	OMA	247			uW	2
Extinction Ratio@4.25Gbps	ER	4			dB	
Relative Intensity Noise	RIN			-120	dB/Hz	
Transmitter and Dispersion Penalty	TDP			1	dB	
Optical Tx Output disable	P_{dis}			-45	dBm	
Optical receiver Characteristics						
Parameter	Symbol	Min	Typical	Max	Unit	Notes
Receiver Sensitivity (BOL)	SEN			-12	dBm	4
Receiver Sensitivity (EOL)				-11		
Wavelength Range	λ_c	770	850	870	nm	
Receiver Reflectance				-12	dB	
Optical Power Input Overload	P_{in-max}	0			dBm	4
LOS	Optical De-assert	P_d		-15	dBm	4
	Optical Assert	P_a	-30			
LOS hysteresis		0.5		5	dB	5

Note1. The supply current is SFP module's working current.

Note2: Equivalent extinction ratio specification for Fiber Channel. Allows smaller ER at higher average power

Note3. Optical transition time is the time interval required for the rising or falling edge of an optical pulse to transition between the 20% and 80% amplitudes relative to the logical 1 and 0 levels

Note4. Measured with a PRBS 2^7-1 test pattern, @4.25Gbps ER=6dB, BER< 10^{-12}

Note5. The LOS Hysteresis minimizes 'chatter' on the output line. In principle, Hysteresis alone does not guarantee chatter-free operation.

Digital Diagnostic Monitoring Information

Parameter	Accuracy	Calibration	Note
Temperature	$\pm 3^\circ\text{C}$	internal	-20~85°C
Voltage	$\pm 3\%$	internal	3.1 to 3.5V
Bias Current	$\pm 10\%$	internal	Specified by normal value
TX Power	$\pm 2\text{dB}$	internal	-9~-2dBm
RX Power	$\pm 2\text{dB}$	internal	-15~0dBm

Pin Description

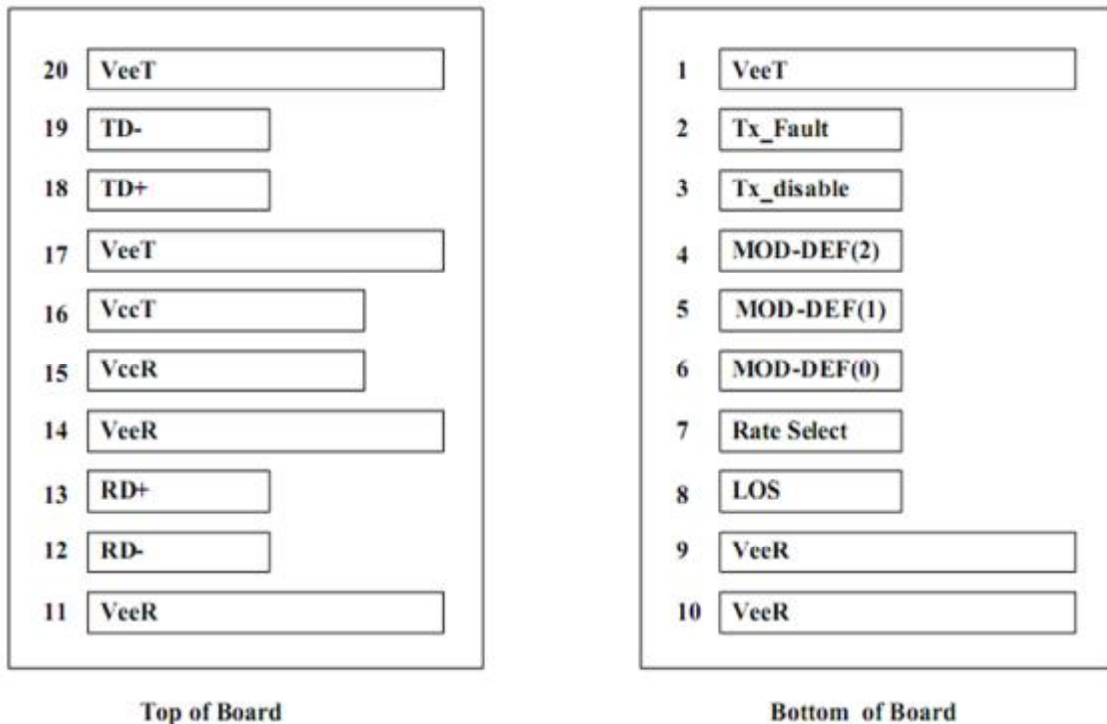

As Viewed Through Top of Board

Pin	Name	Function/Description	Engage-ment	Order
1	VeeT	Transmitter Ground	1	
2	TX Fault	Transmitter Fault Indication	3	1
3	TX Disable	Transmitter Disable-Module disables on high or open	3	2
4	MOD-DEF2	Module Definition 2-Two wire serial ID interface	3	3
5	MOD-DEF1	Module Definition 1-Two wire serial ID interface	3	3
6	MOD-DEF0	Module Definition 0-Two wire serial ID interface	3	3
7	Rate Select	Not Connected	3	
8	LOS	Loss of Signal	3	4
9	VeeR	Receiver Ground	1	
10	VeeR	Receiver Ground	1	
11	VeeR	Receiver Ground	1	
12	RD-	Inverse Received Data out	3	5
13	RD+	Received Data out	3	5
14	VeeR	Receiver Ground	1	
15	VccR	Receiver Power —— +3.3V±5%	2	6
16	VccT	Transmitter Power —— +3.3 V±5%	2	6

17	VeeT	Transmitter Ground	1	
18	TD+	Transmitter Data In	3	7
19	TD-	Inverse Transmitter Data In	3	7
20	VeeT	Transmitter Ground	1	

Note1. TX Fault is open collector/drain output which should be pulled up externally with a 4.7K – 10K Ω resistor on the host board to supply $<V_{ccT}+0.3V$ or $V_{ccR}+0.3V$. When high, this output indicates a laser fault of some kind. Low indicates normal operation. In the low state, the output will be pulled to $<0.8V$.

Note2. TX Disable input is used to shut down the laser output per the state table below. It is pulled up within the module with a 4.7K – 10K Resistor.

Low (0 – 0.8V): Transmitter on;

Between (0.8V and 2V): Undefined High;

(2.0 – V_{ccT}): Transmitter Disabled;

Open: Transmitter Disabled.

Note3. Mod-Def 0, 1, 2. These are the module definition pins. They should be pulled up with a 4.7 – 10K Resistor on the host board to supply less than $V_{ccT}+0.3V$ or $V_{ccR}+0.3V$.

Mod-Def 0 is grounded by the module to indicate that the module is present.

Mod-Def 1 is clock line of two wire serial interface for optional serial ID.

Mod-Def 2 is data line of two wire serial interface for optional serial ID.

Note4. LOS (Loss of signal) is an open collector/drain output which should be pulled up externally with a 4.7 – 10K resistor on the host board to supply $<V_{ccT}+0.3V$ or $V_{ccR}+0.3V$. When high, this output indicates the received optical power is below the worst case receiver sensitivity (as defined by the standard in use). Low indicates normal operation. In the low state, the output will be pulled to $<0.8V$.

Note5. RD-/+: These are the differential receiver outputs. They are AC coupled 100 Ω differential lines which should be terminated with 100 Ω differential at the user SERDES. The AC coupling is done inside the module and thus not required on the host board.

Note6. V_{ccR} and V_{ccT} are the receiver and transmitter power supplies. They are defined as $3.3V\pm5\%$ at the SFP connector pin. The in-rush current will typically be no more than 30mA above steady state supply current after 500ns.

Note7. TD-/+: These are the differential transmitter inputs. They are AC coupled differential lines with 100 Ω differential termination inside the module. The AC coupling is done inside the module and is thus not required on host board.

Block Diagram

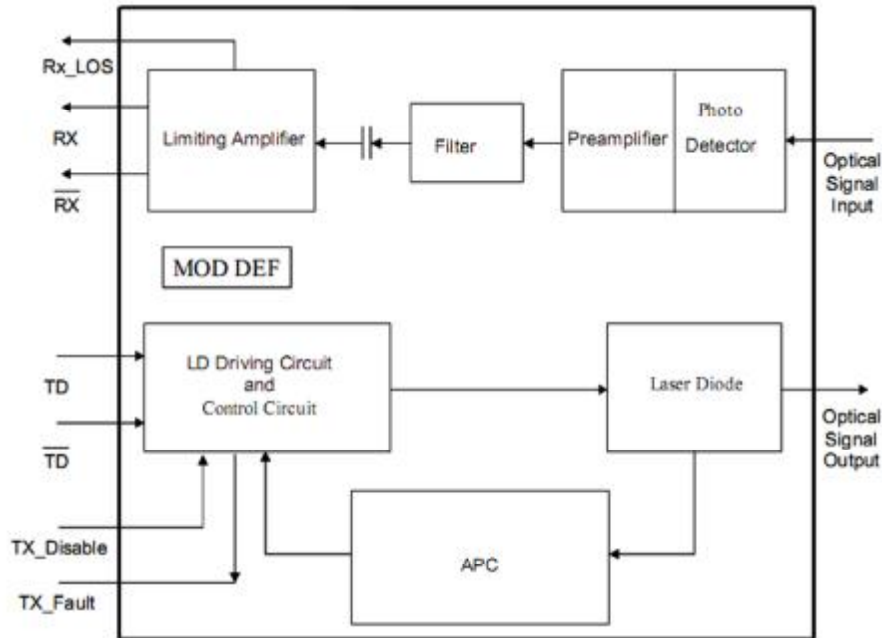

Typical application Circuit

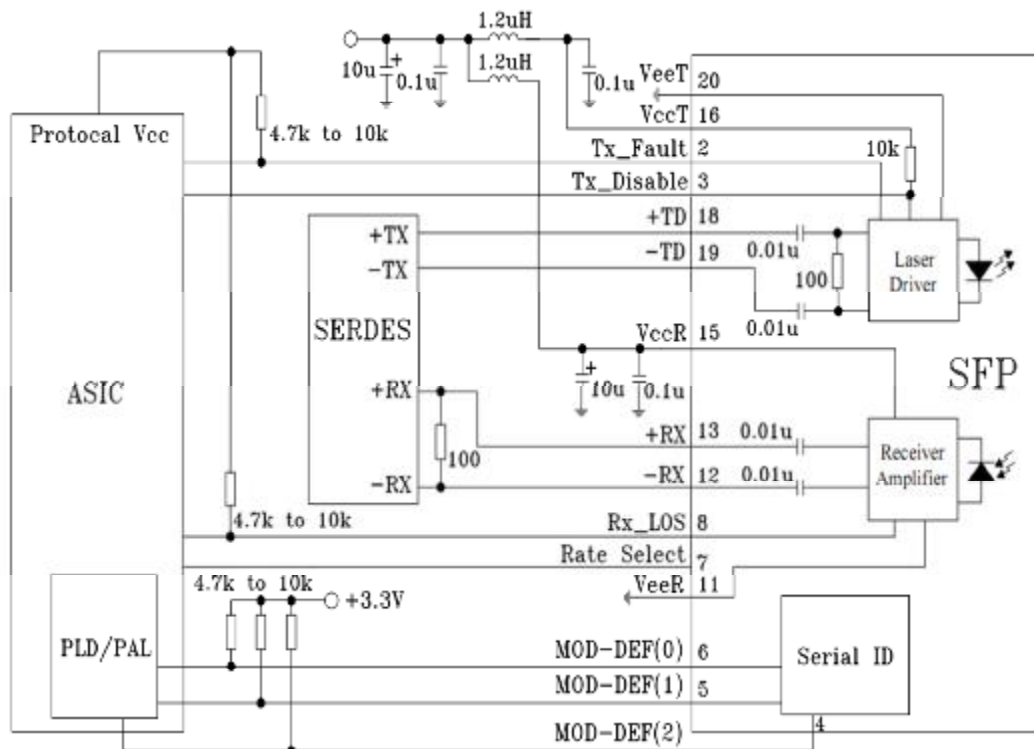

Digital Diagnostic Memory Map

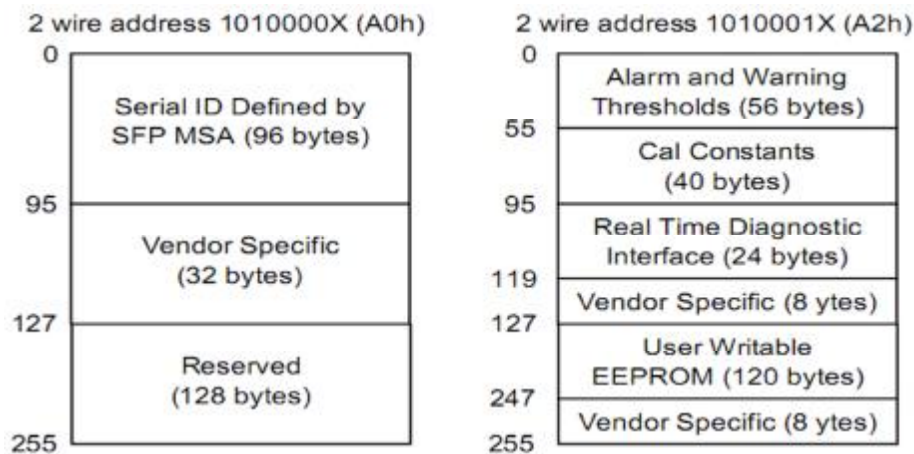

EEPROM Serial ID Memory Contents

The optical transceiver contains an EEPROM. It provides access to sophisticated identification information that describes the transceiver's capabilities, standard interfaces, manufacturer, and other information. When the serial protocol is activated, the host generates the serial clock signal (SCL, Mod Def 1). The positive edge clocks data into those segments of the EEPROM that are not writing protected within the SFP transceiver. The negative edge clocks data from the SFP transceiver. The serial data signal (SDA, Mod Def 2) is bi-directional for serial data transfer. The host uses SDA in conjunction with SCL to mark the start and end of serial protocol activation. The memories are organized as a series of 8-bit data words that can be addressed individually or sequentially.

The Module provides diagnostic information about the present operating conditions. The transceiver generates this diagnostic data by digitization of internal analog signals. Calibration and alarm/warning threshold data is written during device manufacture. Received power monitoring, transmitted power monitoring, bias current monitoring, supply voltage monitoring and temperature monitoring all are implemented. The diagnostic data are raw A/D values and must be converted to real world units using calibration constants stored in EEPROM locations 56 – 95 at wire serial bus address A2h. The digital diagnostic memory map specific data fields define as following.

EEPROM Serial ID Memory Contents (2-Wire Address A0h)

Address	Name of field	Hex	Description
BASE ID Fields			
00	Identifier	03	SFP transceiver
01	Ext. Identifier	04	Serial ID module supported for SFP
02	Connector	07	LC
03-10	Transceiver Codes		

11	Encoding	01	Encoding codes
12	BR, Nominal	2B	Nominal 4250Mbps transmitter
13	Rate Identifier	00	Not defined
14	Length(9um)-km	00	Transceiver transmit distance
15	Length(9um)-m	00	
16	Length(50um)	0F	
17	Length(62.5um)	07	
18	Length(cable)	00	
19	Length(OM3)	00	
20-35	Vendor Name	4D 45 4E 54 45 43 48 4F 50 54 4F...	"MENTECHOPTO"(ASCII character)
36	Reserved	00	Not defined
37-39	Vendor OUI	00 00 00	Not defined
40-55	Vendor P/N		
56-59	Vendor P/N Rev.	312E30 20	"1.0"(ASCII character)
60-61	Laser Wavelength	0352	850nm
62	Reserved	00	Not defined
63	CC_BASE	XX	Check sum of bytes 0-62
Extended ID Fields			
64-65	Options	00 1A	RX_LOS、TX_Faultare implemented
66	BR, max	14	Upper bit rate margin,20%
67	BR, min	14	Lower bit rate margin,20%
68-83	Vendor SN		Vendor Serial Number in ASCII character
84-91	Date Code	Data Code	Vendor Date Code in ASCII character
92	Diagnostic Monitoring Type	68	Digital Diagnostic monitoring implemented "Internally calibrated" is implemented, RX measurement type is "Average Power"
93	Enhanced options	F0	Optional Alarm/warning flags, soft Tx_Fault monitoring, soft LOS monitoring are implemented
94	SFF-8472 compliant	05	SFF-8472 compliant with revision 11.0
95	CC-EXT	XX	Check sum of bytes 64-94
Vendor Specific ID Field			
96-127	Vendor Specific	00	Vendor specific EEPROM
128-255	Reserved	00	Reserved for future use

Digital Diagnostic Monitoring Interface: Alarm and Warning Thresholds

(2-Wire Address A2h)

Address	#Bytes	Name	Real Value		Unit	Hex
00-01	2	Temp High Alarm	80	100	°C	
02-03	2	Temp Low Alarm	-10	-30	°C	
04-05	2	Temp High Warning	70	85	°C	
06-07	2	Temp Low Warning	0	-15	°C	
08-09	2	Voltage High Alarm	3.7		V	
10-11	2	Voltage Low Alarm	3		V	
12-13	2	Voltage High Warning	3.5		V	
14-15	2	Voltage Low Warning	3.1		V	
16-17	2	Bias High Alarm	20		mA	
18-19	2	Bias Low Alarm	0		mA	
20-21	2	Bias High Warning	15		mA	
22-23	2	Bias Low Warning	0.5		mA	
24-25	2	TX Power High Alarm	-0.5		dBm	
26-27	2	TX Power Low Alarm	-11		dBm	
28-29	2	TX Power High Warning	-2.5		dBm	
30-31	2	TX Power Low Warning	-9		dBm	
32-33	2	RX Power High Alarm	2		dBm	
34-35	2	RX Power Low Alarm	-14		dBm	
36-37	2	RX Power High Warning	0		dBm	
38-39	2	RX Power Low Warning	-12		dBm	
40-55	16	Reserved	Reserved			

Package Outline

Dimensions are in millimeters. (unit: mm)

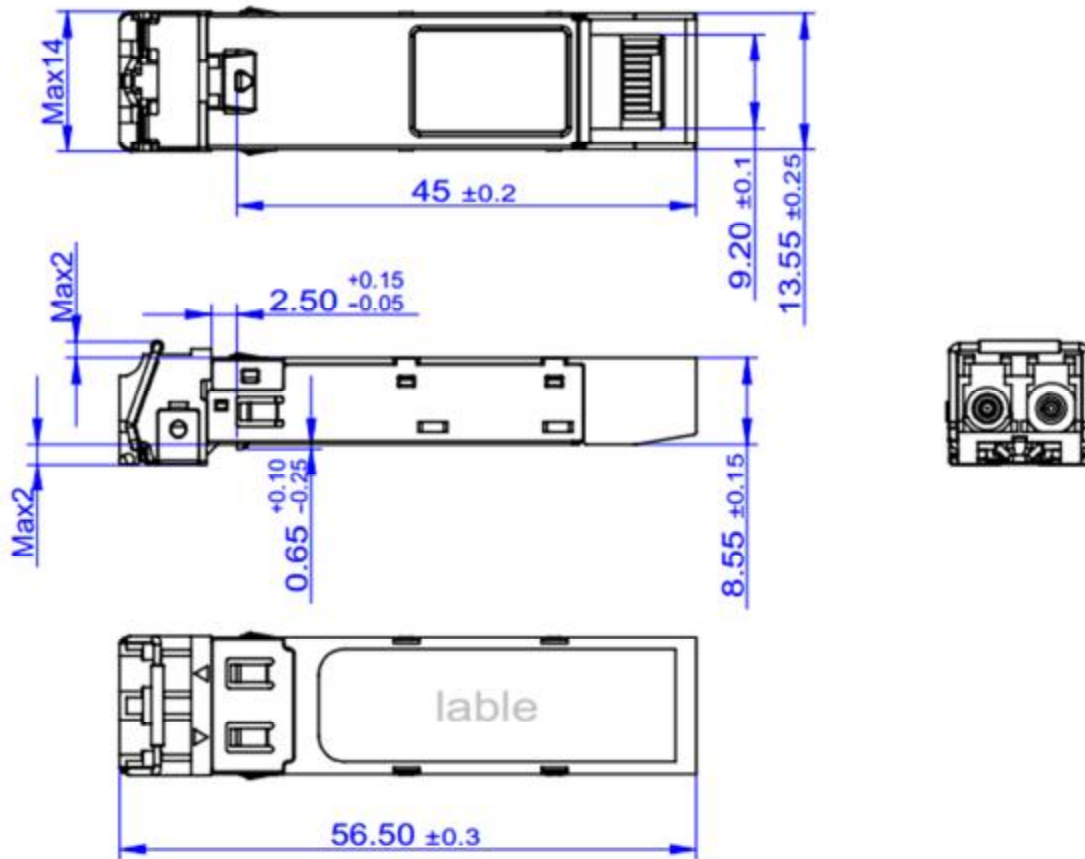

Regulatory Compliance

Feature	Test	Method
Electrostatic Discharge (ESD) to the Electrical Pins	MIL-STD-883E Method 3015.7	Class 1(>1000V for SFI pins, >2000Vfor other pins.)
Electrostatic Discharge (ESD) Immunity	IEC61000-4-2	Class 2(>4.0kV)
Electromagnetic Interference (EMI)	CISPR22 ITE Class B FCC Class B CENELEC EN55022 VCCI Class 1	Comply with standard
Immunity	IEC61000-4-3	Comply with standard
Eye Safety	FDA 21CFR 1040.10 and 1040.11 EN (IEC) 60825-1,2	Compatible with Class I laser Product

Ordering information

Part. No	Specifications								
	Pack	Rate (Gbps)	Tx (nm)	Po (dBm)	RX	Sen (dBm)	Temp (°C)	Reach (m)	DDM
S4FD2-D0C-8VT1	SFP	4.25	850	-9 ~-2.5	PIN	<-12	0~70	150	DDM; RoHS
S4FD2-D0R-8VT1	SFP	4.25	850	-9 ~-2.5	PIN	<-12	-20~85	150	DDM; RoHS